

IMPORTANT INSTRUCTIONS

For Installation LS343 Human Touch Retro-Fit Kits

Warning: The Luminaire should only be used complete with its protective shield (cover)

Lumascap Lighting Industries Pty Ltd
38-44 Enterprise Street, Cleveland, QLD 4163, Australia
PO Box 1875, Cleveland D.C., QLD 4163, Australia
T 07 3286 2299
F 07 3286 6599
E sales@lumascap.com.au
W www.lumascap.com.au

CAUTION - This Product Must Only Be Installed/fitted By A Licensed Electrical Worker

WARNING

DO NOT SHORTEN, INTERFERE OR DISCONNECT CABLE FROM FITTING. WARRANTY WILL BE VOID IF CABLE ASSEMBLY IS TAMPERED WITH.

Instruction Guide

IMPORTANT NOTE:

Human Touch kits are available for LS343 series fixtures in 290mm & 350mm Bodies ONLY!

LS692

1

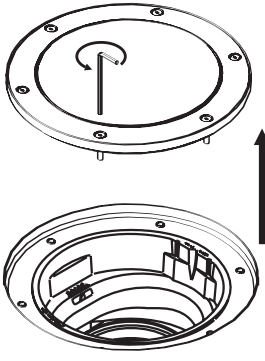

Isolate and remove Lid
Check the fixture is electrically isolated.
Unscrew & remove lid.

2

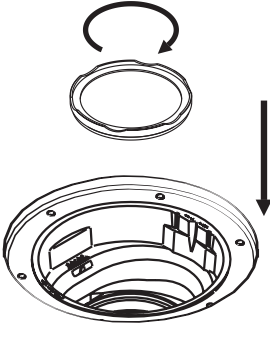

Screw in filter
Screw filter onto filter ring

3

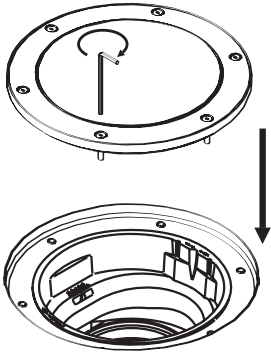

Close fixture

LS693

1

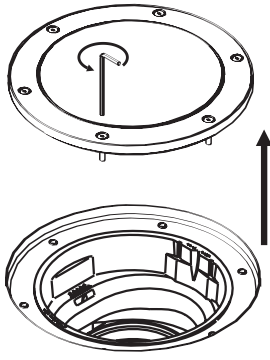

Isolate and remove Lid
Check the fixture is electrically isolated.
Unscrew & remove lid.

2

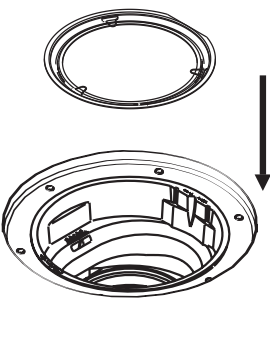

Insert filter
Align keyed edge of filter with fixture and drop into place

3

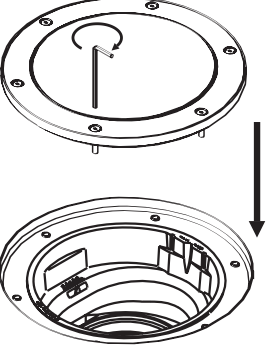

Close fixture

IMPORTANT SAFETY INSTRUCTIONS

WARNING - To reduce the risk of FIRE or INJURY:

1. Luminaires and transformers to be installed by qualified installers only.
2. Luminaires to be used for intended purpose only. e.g Wall Mount fittings must be wall mounted.
3. Luminaires can become very hot. Use discretion in placement.
4. Do not touch hot lens, guard, or enclosure.
5. CAUTION - HOT SURFACE. Keep away from curtains and other combustible material.
6. Turn Off/Unplug and allow to cool before replacing lamp.
7. Keep lamp away from materials that may burn.
8. Never touch lamp with bare fingers. Oil from skin may damage lamp. Hold lamp with soft cloth when installing or replacing.
9. Do not operate the luminaires with a missing or damaged parts.
10. Replace any cracked protective shield
11. Use only lamp type, voltage and wattage as specified by Lumascap on the product label.
12. Use only genuine Lumascap parts to replace damaged or missing components.
13. Luminaires supplied with Loctite Silver Grade Anti Seize lubricant on threads. Reapply if needed.
14. Refer to instructions for installation and operating requirements.
15. Ensure installation complies with local regulations

SAVE THESE INSTRUCTIONS.

LUMASCAPE
 HEAD OFFICE - QLD
 Tel (07) 3286 2299
 Fax (07) 3286 6599

LUMASCAPE
 SYDNEY - NSW
 Tel (02) 9519 6860
 Fax (02) 9519 8834

LUMASCAPE
 MELBOURNE - VIC
 Tel (03) 9686 1900
 Fax (03) 9686 1700

LUMASCAPE USA INC.
 SAN FRANCISCO - CA
 Tel 1-(650)-595-5862
 Fax 1-(650) 595-5820

H.I. LIGHTING
 LUMASCAPE AGENT - WA
 Tel (08) 9321 5422
 Fax (08) 9321 5881

LIGHTING PARTNERS AUSTRALIA
 LUMASCAPE AGENT - SA
 Tel (08) 8232 0074
 Fax (08) 8232 0076

NQ LIGHTING
 LUMASCAPE AGENT - NTH QLD
 Tel (07) 4031 4490
 Fax (07) 4031 5933

ECC LIGHTING
 LUMASCAPE AGENT - NZ
 Tel (09) 379 9680
 Fax (09) 308 9328