

# IMPORTANT INSTRUCTIONS

For Installation LS640 / LS6052-K / LS6058-K

Warning: The Luminaire should only be used complete with its protective shield (cover)

Lumascope Lighting Industries Pty Ltd  
38-44 Enterprise Street, Cleveland, QLD 4163, Australia  
PO Box 1875, Cleveland D.C., QLD 4163, Australia  
T 07 3286 2299  
F 07 3286 6599  
E sales@lumascope.com.au  
W www.lumascope.com.au

## CAUTION - This Product Must Only Be Installed/fitted By A Licensed Electrical Worker

1

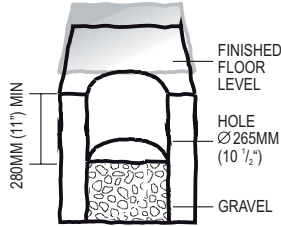

### HOLE DETAIL - SECTION VIEW

- Layout fixture locations as required.
- Use discretion in placement, fixture may become hot and could burn.
- Fixture cavity should be as above. Ensure gravel or similar medium forms the bottom of cavity to allow drainage.

2

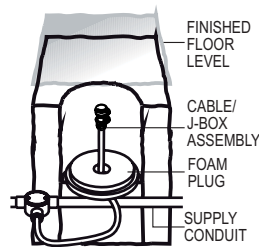

### SUPPLY CONNECTION

- Connect junction box supplied to supply conduit as per instructions.
  - Punch a hole in foam plug large enough for the connector to pass through
  - Pack hole in plug around the cable to ensure concrete doesn't enter the fixture cavity.
- (Ensure the cap on the connector is secure)

3

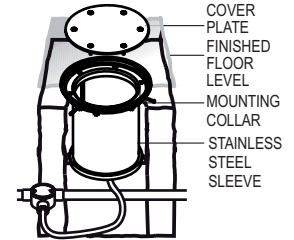

### FIT SLEEVE, COLLAR AND COVER PLATE

- Fit sleeve over foam plug.
- Ensure enough cable is in the cavity to connect to fixture.
- Position top lip of mounting collar to be flush with finished floor level.
- Screw cover plate, (Available separately, consult your Lumascope dealer), to mounting collar if required.

4

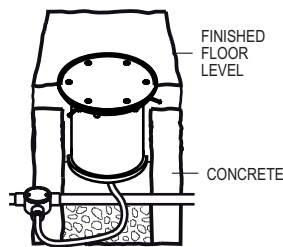

### POUR CONCRETE

- Pour concrete. Check the top surface of mounting collar is flush with the finished floor level.

5

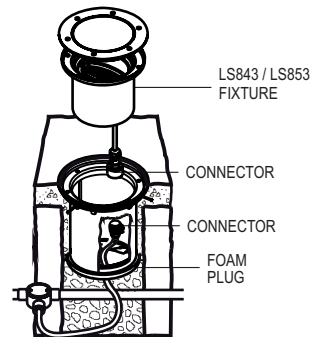

### FIT LS843 / LS853 FIXTURE

- When ready to install fixture; Destroy Foam plug.
- Assemble fixture according to fixture Instruction sheet.
- Remove cover plate (if located).
- Join Quick Connectors (do not dispose of cap).

6

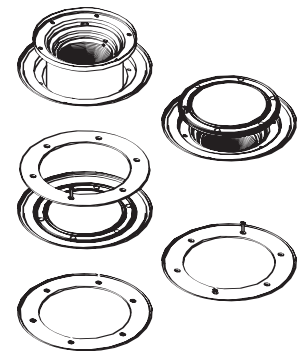

### LID TIGHTENING PROCEDURE

1. Insert fixture body aligning holes.
2. Use screw to insert/align seal
3. Insert lid and start only, 1 screw.
4. Insert screw opposite and tighten
5. Insert and tighten all screws.

**Do not over tighten.**  
Ensure seal/sealing surface is free from debris.

### GENERAL ASSEMBLY

Finished Floor Level to be flush with top surface of brass collar.

Factory supplied J-Box, epoxy sealed entry. Ensure lid is replaced.

Use epoxy sachet supplied to fill j-box after connections have been made to ensure water-proofing. Refer Lumascope instruction sheet "For Installation of LS630/LS640-K Connection Box" for connection information.

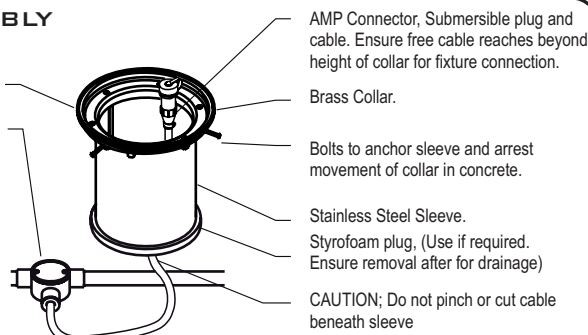

Epoxy sachet not supplied outside Australia. To be supplied by contractor.

3M Scotch Cast 2112 is recommended as a suitable epoxy by Lumascope.

Further information over page

www.lumascope.com.au

# B IMPORTANT INSTRUCTIONS

For Installation LS640 / LS6052-K / LS6058-K

Warning: The Luminaire should only be used complete with its protective shield (cover)

Lumascope Lighting Industries Pty Ltd  
38-44 Enterprise Street, Cleveland, QLD 4163, Australia  
PO Box 1875, Cleveland D.C., QLD 4163, Australia  
T 07 3286 2299  
F 07 3286 6599  
E sales@lumascope.com.au  
W www.lumascope.com.au

**CAUTION - This Product Must Only Be Installed/fitted By A Licensed Electrical Worker**

1

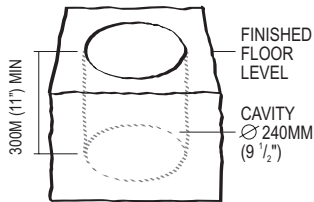

### CAVITY REQUIREMENTS

Layout fixture locations as required.  
Use discretion in placement, fixture may become hon and could burn.  
Fixture cavity requirements are as shown above.

2

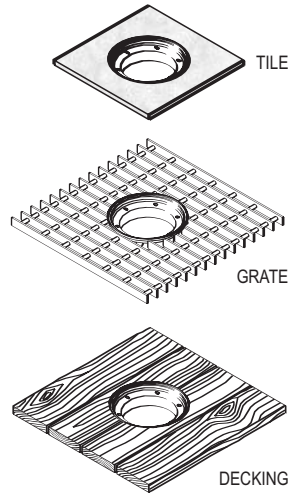

### MOUNT COLLAR

Mount collar securely as required in floor media.

3

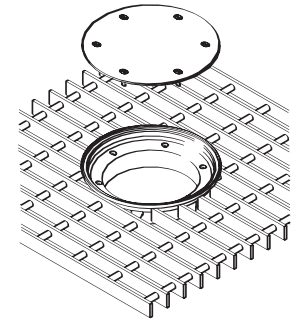

### TEMPORARY COVER PLATE

If installation of fixture into mounting collar is to be delayed we recommend the installation of a cover plate. These are available from Lumascope, please consult your dealer,

4

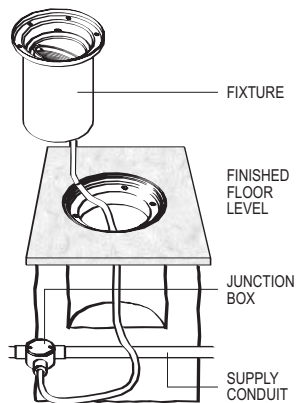

### SUPPLY CONNECTION

If fixture is ordered with junction box cable entry, connect according to junction box installation instructions and local wiring rules. If ordered without junction box assembly, connect in accordance with local wiring rules.

5

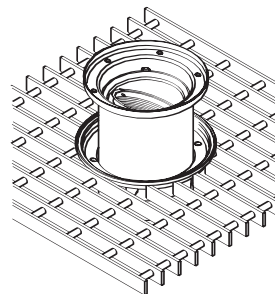

### MOUNT FIXTURE

Insert fixture into mounting collar aligning holes in the flange with tapped holes in the collar

6

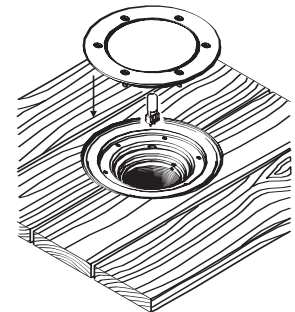

### LAMP, TEST, SEAL.

Complete installation of fixture by inserting lamp, testing and sealing, (As per Instruction 6 over.) according to the LS843/LS853 installation instruction sheet.

[www.lumascope.com.au](http://www.lumascope.com.au)

## IMPORTANT SAFETY INSTRUCTIONS

### WARNING - To reduce the risk of FIRE or INJURY:

1. Luminaires and transformers to be installed by qualified installers only.
2. Luminaires to be used for intended purpose only. e.g Wall Mount fittings must be wall mounted.
3. Luminaires can become very hot. Use discretion in placement.
4. Do not touch hot lens, guard, or enclosure.
5. CAUTION - HOT SURFACE. Keep away from curtains and other combustible material.
6. Turn Off/Unplug and allow to cool before replacing lamp.
7. Keep lamp away from materials that may burn.
8. Never touch lamp with bare fingers. Oil from skin may damage lamp. Hold lamp with soft cloth when installing or replacing.
9. Do not operate the luminaires with a missing or damaged parts.
10. Replace any cracked protective shield
11. Use only lamp type, voltage and wattage as specified by Lumascap on the product label.
12. Use only genuine Lumascap parts to replace damaged or missing components.
13. Luminaires supplied with Loctite Silver Grade Anti Seize lubricant on threads. Reapply if needed.
14. Refer to instructions for installation and operating requirements.
15. Ensure installation complies with local regulations

### SAVE THESE INSTRUCTIONS.

LUMASCAPE  
 HEAD OFFICE - QLD  
 Tel (07) 3286 2299  
 Fax (07) 3286 6599

LUMASCAPE  
 SYDNEY - NSW  
 Tel (02) 9519 6860  
 Fax (02) 9519 8834

LUMASCAPE  
 MELBOURNE - VIC  
 Tel (03) 9686 1900  
 Fax (03) 9686 1700

LUMASCAPE USA INC.  
 SAN FRANCISCO - CA  
 Tel 1-(650)-595-5862  
 Fax 1-(650) 595-5820

H.I. LIGHTING  
 LUMASCAPE AGENT - WA  
 Tel (08) 9321 5422  
 Fax (08) 9321 5881

LIGHTING PARTNERS AUSTRALIA  
 LUMASCAPE AGENT - SA  
 Tel (08) 8232 0074  
 Fax (08) 8232 0076

NQ LIGHTING  
 LUMASCAPE AGENT - NTH QLD  
 Tel (07) 4031 4490  
 Fax (07) 4031 5933

ECC LIGHTING  
 LUMASCAPE AGENT - NZ  
 Tel (09) 379 9680  
 Fax (09) 308 9328