

LS393 - 293 X B 81 XK 21 P 7

MR16, borosilicate lens, polished stainless steel
recessed cover configuration depicted



LS393 - 293 X D 81 XK 21 P 7

MR16, borosilicate lens, polished stainless steel
round flush cover configuration depicted



LS393 - 293 X U 81 XK 21 P 7

MR16, borosilicate lens, polished stainless steel
square flush cover configuration depicted



LS393 - 293 A M 85 XK 23 R 7

MR16, **OptiClear™** lens, polished stainless steel
flush pre-installation cover configuration depicted

Note: To specify for pre-installation order with **LS647-K**
pre-installation / concrete blackout kit



C762 20-06-2008

| Lighting Designer | Fixture |
|-------------------|---------|
| | |
| Supplier | |

SOURCE

12V, MR16 (50W max)

Remote or integral transformer only (order separately)

FEATURES

Ingress protection rating - IP68

OptiClear™ max static load - 3750kg

Applied to a 50mm diameter area in the centre of the glass

Corrosion resistant 316 stainless steel
- marine grade

Modular design, adjustable gimbal for easy installation and maintenance

Adjustable lamp angle to 20°

Non-galling clinch nuts dramatically reduce cross threading or binding

Self resetting thermal protection device to protect unit from overheating

Corrosion resistant stainless steel cover fasteners

Internal honeycomb louvre

OPTIONS

HumanTouch™ total temperature reduction technology

OptiClear™ lens for increased efficiency

High optical transmission, toughened

GripGlass™ slip resistant safety glass

Recessed, round flush and square flush covers

Installation

- Direct burial
- Mounting collar (decks and grates)
- Pre-installation (concrete blackout and drive-over)



humantouch™



gripglass™

Any luminaire can become hot – caution should always be used in both appropriate use and placement

Lumascap will guarantee the following product groups from the date of purchase against faulty workmanship or materials as stated below and subject to the terms and conditions published in the Lumascap catalogue and at www.lumascap.com.au. Architectural lighting product group - structural warranty: spotlights & floodlights - aluminium fixtures, 2 years; in ground - stainless steel fixtures, 10 years; underwater - stainless steel & brass fixtures, 5 years; wall mount - stainless steel fixtures, 10 years; wall mount - aluminium fixtures, 2 years; wall mount - brass fixtures, 5 years; bollard & pathway - stainless steel fixtures, 10 years; down lights - aluminium fixtures, 2 years; landscape lighting product group - structural warranty: copper fixtures, 10 years, aluminium fixtures, 2 years, electronic transformers, 12 months, magnetic transformers, 12 months, electrical warranty all product groups: 12 months.

LUMASCAPE
HEAD OFFICE - QLD
Tel (07) 3286 2299
Fax (07) 3286 6599

LUMASCAPE
SYDNEY - NSW
Tel (02) 9519 6860
Fax (02) 9519 8834

LUMASCAPE
MELBOURNE - VIC
Tel (03) 9686 1900
Fax (03) 9686 1700

LUMASCAPE USA INC.
SAN FRANCISCO - CA
Tel 1-(650)-595-5862
Fax 1-(650) 595-5820

H.I. LIGHTING
LUMASCAPE AGENT - WA
Tel (08) 9321 5422
Fax (08) 9321 5881

LIGHTING PARTNERS AUSTRALIA
LUMASCAPE AGENT - SA
Tel (08) 8232 0074
Fax (08) 8232 0076

NQ LIGHTING
LUMASCAPE AGENT - NTH QLD
Tel (07) 4031 4490
Fax (07) 4031 5933

ECC LIGHTING
LUMASCAPE AGENT - NZ
Tel (09) 379 9680
Fax (09) 308 9328

COVERS & INSTALLATION TYPES

Recessed Cover

Where no cover overhang is desired

Depicted previous page

- SS316: Polished
- SS316: Brushed
- Brass: Polished

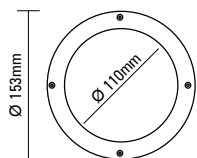

Round Flush Cover

For surfaces where the cover has to conceal a gap between luminaire and surround

Depicted previous page

- SS316: Polished
- SS316: Brushed
- Brass: Polished

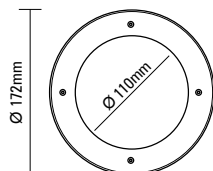

Square Flush Cover

For surfaces where the cover has to conceal a gap between luminaire and surround

Depicted previous page

- SS316: Polished
- SS316: Brushed
- Brass: Polished

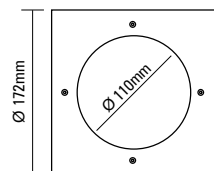

Direct Burial

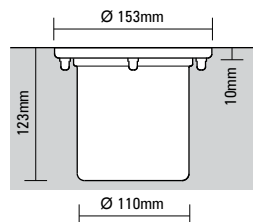

Direct Burial

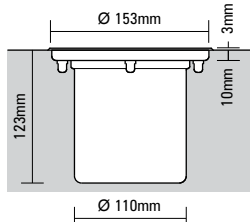

Direct Burial

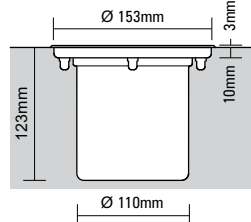

Mounting Collar Flush Cover

For use with pre-installation kit

Depicted previous page

- SS316: Polished
- SS316: Brushed
- Brass: Polished
- Brass: Brushed

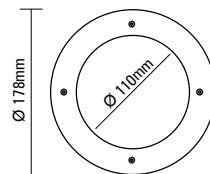

Pre-installation Cover

For use with pre-installation kit

Depicted previous page

- SS316: Polished
- SS316: Brushed
- Brass: Polished
- Brass: Brushed

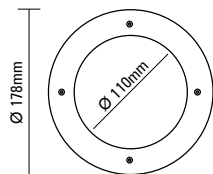

LS647 Mounting Collar for Decks and Grates

Sold separately as accessory

For installation in decks and grates. May also be used in hollow floors where there is appropriate ventilation

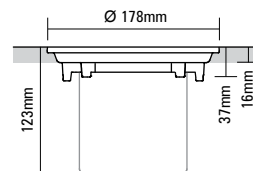

LS647-K and LS647-K-MV Pre-Installation Kit for Concrete and Drive-over

Sold separately as accessory

For drive-over or for concrete and similar installations, and for when it may be preferable to install mounting location and cable before installing luminaire

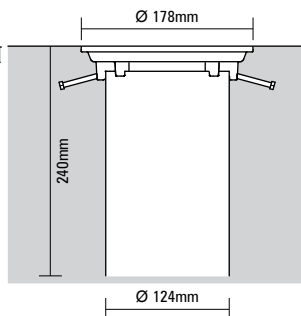

LS647-K

For low voltage

647-K-MV

For mains voltage

LENS OPTIONS

Borosilicate Glass

Ideal for general use areas
Not suitable for drive-over application



OptiClear™ Glass

Glass of very high optical purity and load strength



GripGlass™

OptiClear™ glass with slip reduction glazing process

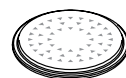

OPTICAL SYSTEM

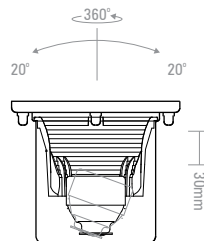

Adjustable
MR16

Lumascap will guarantee the following product groups from the date of purchase against faulty workmanship or materials as stated below and subject to the terms and conditions published in the Lumascap catalogue and at www.lumascap.com.au. Architectural lighting product group - structural warranty: spotlights & floodlights - aluminium fixtures, 2 years; in ground - stainless steel fixtures, 10 years; underwater - stainless steel & brass fixtures, 5 years; wall mount - stainless steel fixtures, 10 years; wall mount - aluminium fixtures, 2 years; wall mount - brass fixtures, 5 years; bollard & pathway - stainless steel fixtures, 10 years; down lights - aluminium fixtures, 2 years; landscape lighting product group - structural warranty: copper fixtures, 10 years, aluminium fixtures, 2 years, electronic transformers, 12 months, magnetic transformers, 12 months, electrical warranty all product groups: 12 months.

LUMASCAPE
HEAD OFFICE - QLD
Tel (07) 3286 2299
Fax (07) 3286 6599

LUMASCAPE
SYDNEY - NSW
Tel (02) 9519 6860
Fax (02) 9519 8834

LUMASCAPE
MELBOURNE - VIC
Tel (03) 9686 1900
Fax (03) 9686 1700

LUMASCAPE USA INC.
SAN FRANCISCO - CA
Tel 1-(650)-595-5862
Fax 1-(650) 595-5820

H.I. LIGHTING
LUMASCAPE AGENT - WA
Tel (08) 9321 5422
Fax (08) 9321 5881

LIGHTING PARTNERS AUSTRALIA
LUMASCAPE AGENT - SA
Tel (08) 8232 0074
Fax (08) 8232 0076

NQ LIGHTING
LUMASCAPE AGENT - NTH QLD
Tel (07) 4031 4490
Fax (07) 4031 5933

ECC LIGHTING
LUMASCAPE AGENT - NZ
Tel (09) 379 9680
Fax (09) 308 9328

CABLE ENTRY OPTIONS

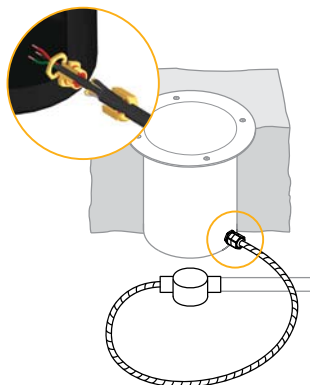

FOR DIRECT BURIAL

Armoured Cable and J-Box

0.6m provides armoured cable protection against damage to cable between luminaire and J-Box (included) negating need to further insulate with conduit.

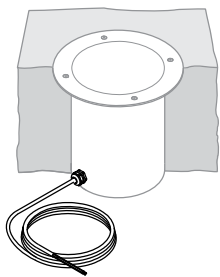

FOR DIRECT BURIAL

Single Gland Entry, Anti-leach Cable

MicroAntiLeach™ and 3m cable provides additional protection to luminaire against water ingress via cable.

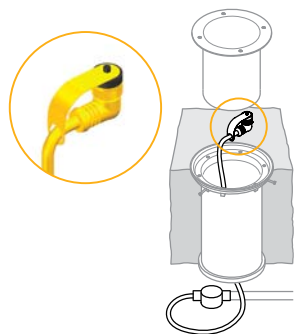

FOR PRE-INSTALLATION

IP68 Connector and J-Box

For use with LS647-K and LS647-K-MV pre-installation kit for concrete blockout and drive-over applications. Supplied with IP68 connector, 0.8m cable connected to J-Box.

CABLE ENTRY LOCATION

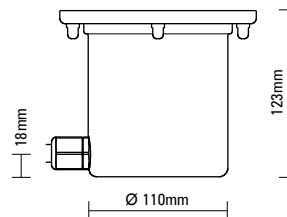

Side entry

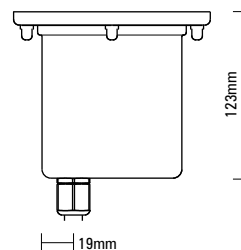

Bottom entry

Lumascap will guarantee the following product groups from the date of purchase against faulty workmanship or materials as stated below and subject to the terms and conditions published in the Lumascap catalogue and at www.lumascap.com.au. Architectural lighting product group - structural warranty: spotlights & floodlights - aluminium fixtures, 2 years; in ground - stainless steel fixtures, 10 years; underwater - stainless steel & brass fixtures, 5 years; wall mount - stainless steel fixtures, 10 years; wall mount - aluminium fixtures, 2 years; wall mount - brass fixtures, 5 years; bollard & pathway - stainless steel fixtures, 10 years; down lights - aluminium fixtures, 2 years; landscape lighting product group - structural warranty: copper fixtures, 10 years, aluminium fixtures, 2 years, electronic transformers, 12 months, magnetic transformers, 12 months, electrical warranty all product groups: 12 months.

| | | | | | | | |
|--|---|--|--|---|---|--|--|
| LUMASCAPE HEAD OFFICE - QLD Tel (07) 3286 2299 Fax (07) 3286 6599 | LUMASCAPE SYDNEY - NSW Tel (02) 9519 6860 Fax (02) 9519 8834 | LUMASCAPE MELBOURNE - VIC Tel (03) 9686 1900 Fax (03) 9686 1700 | LUMASCAPE USA INC. SAN FRANCISCO - CA Tel 1-(650)-595-5862 Fax 1-(650) 595-5820 | H.I. LIGHTING LUMASCAPE AGENT - WA Tel (08) 9321 5422 Fax (08) 9321 5881 | LIGHTING PARTNERS AUSTRALIA LUMASCAPE AGENT - SA Tel (08) 8232 0074 Fax (08) 8232 0076 | NQ LIGHTING LUMASCAPE AGENT - NTH QLD Tel (07) 4031 4490 Fax (07) 4031 5933 | ECC LIGHTING LUMASCAPE AGENT - NZ Tel (09) 379 9680 Fax (09) 308 9328 |
|--|---|--|--|---|---|--|--|