



The EB2 is a compact, factory-sealed inground luminaire designed for harsh exterior environments. With a corrosion-resistant brass body, IP68 rating, and micro-antileach cable entry, it delivers long-term reliability in coastal, urban, or high-moisture settings—no drainage required.

This direct view marker light supports static white outputs with a DALI control option or as non-dimmable.

Optical accessories like an external glare shield and the option to install custom graphic masks make the luminaire fit for any job. The lid comes in brass or stainless steel finishes:

- Brass develops an elegant natural patina over time.
- Cast 316 stainless steel offers superior corrosion resistance; the naturally patterned crystalline surface is indicative of its high-alloy composition, highlighting durability in high-salinity, high-exposure environments.

Drive-over rated and compact at 4.7" (120 mm) diameter, the EB2 delivers up to 210 lm. It installs easily via direct burial, pre-installation kits, or a 4" conduit system, making it ideal for discreet yet powerful architectural or landscape lighting.

### Performance

Static White	Lumen Output (lm)	Efficacy (lm/W)	Peak Intensity (cd)
● 2,700 K (80 CRI)	190	43	70
● 3,000 K (80 CRI)	190	43	70
○ 3,500 K (80 CRI)	190	43	70
● 4,000 K (80 CRI)	210	47	78

Alternative LED colors and CRIs available on request.



Products and specifications are subject to change without notice. LS3328\_250717

### Electrical

<b>Power Consumption</b>	5 W
<b>Lifetime</b>	76,554 hours @ 25°C Ambient (B10, L90, TM21 Projected)
<b>Input Voltage</b>	International: 220-240 V AC, 50 Hz North America: 120 V AC, 60 Hz Low Voltage: 24 V DC
<b>Thermal Management</b>	CoolDrive™ onboard thermal monitoring and control

### Control

<b>Protocols</b>	DALI® (International), Non-Dimmable
------------------	-------------------------------------

### Physical

<b>Housing</b>	Die-cast brass body with stainless-steel or brass lid
<b>Installation</b>	Pre-Installation blockout for concrete pour, drive-over and general use applications. Conduit Mount for mounting in 4" SCH 40 conduit by others. Direct burial for landscapes, planters and special applications.
<b>Adjustability</b>	
<b>Wiring</b>	84 (flexible cable), 82 (½" NPT) Direct Burial and Pre-Install
<b>Ambient Operating Temperature</b>	-40°F to 122°F (-40°C to 50°C)
<b>Surface Temperature</b>	< 149°F (< 65°C)
<b>Weight</b>	4.2 lb (1.9 kg)
<b>Drive-Over</b>	With pre-installation kit (LS6388) installed in concrete as per instructions <sup>3</sup>

<sup>3</sup> With soft tires at low speed, no braking or changing direction.

### Certification & Compliance

<b>IP Rating</b>	IP68
<b>IK Rating</b>	IK8
<b>Static Load Rating</b>	6,614 lb (3,000 kg)
<b>Environment</b>	Dry, Damp, Wet Locations Inherently protected Suitable for use in poured concrete No drainage required
<b>Certifications</b>	UL (USA & Canada), CE, RCM, FCC

Dimensions - Direct Burial (Optional External Glare Shield also depicted)

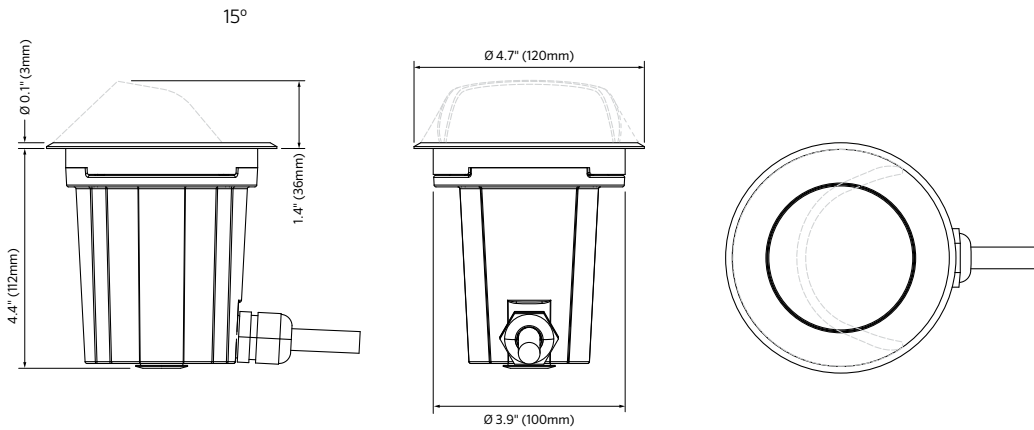

Dimensions - Pre-Install (LS6388)

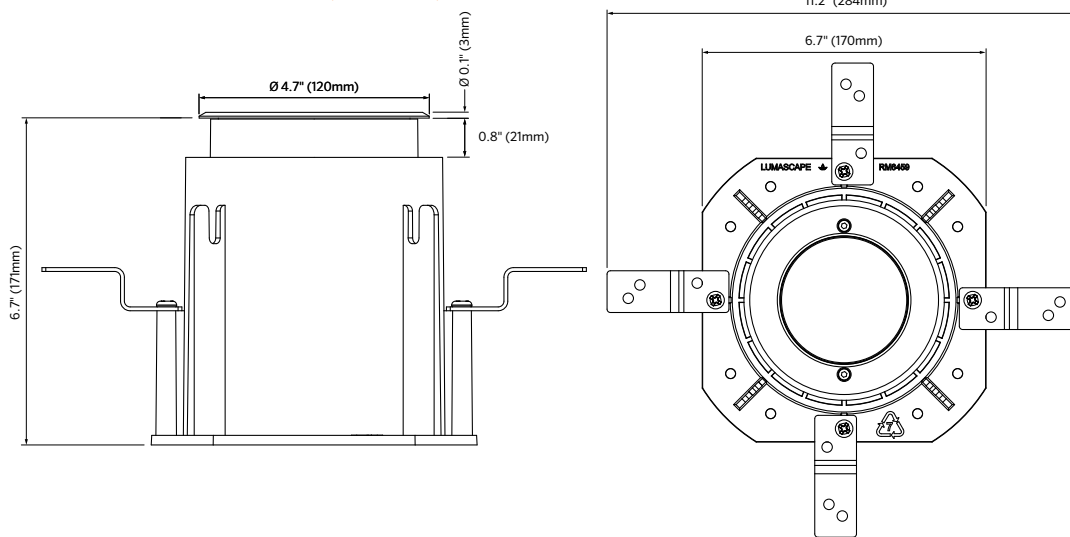

Dimensions - Conduit Mount (LS6389)

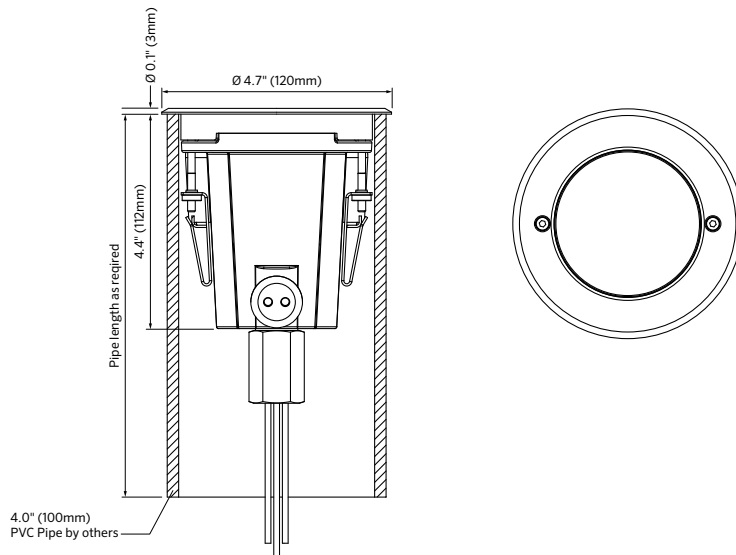

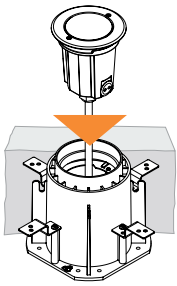

**Pre-Installation Blockout**

This type of installation requires the LS6388 Pre-Installation Kit (ordered separately), which acts as a concrete blockout and is intended for installation before the luminaire. This method ensures the luminaire itself is not damaged during concreting or other site works.

Used for	Drive over applications General use applications Concrete pour applications where luminaire is to be installed after site work has been completed.
Benefits	Easy removal for servicing
Accessories	LS6388 Pre-Installation Blockout

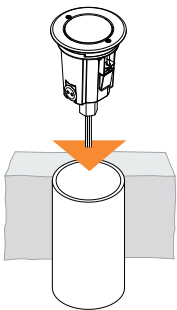

**Conduit Mount**

This type of installation allows the luminaire to be installed and locked into a standard schedule 40, 4" (100mm) conduit (supplied by others). This ensures the luminaire itself is not damaged during concreting or other site works. Once all the site work is completed the luminaire can be installed.

Used for	Drive over applications General use applications Concrete pour applications where luminaire is to be installed after site work has been completed.
Benefits	Easy removal for servicing Schedule 40, 4" (100mm) conduit can be procured locally, prior to delivery of luminaire.

**Connection type '84'**

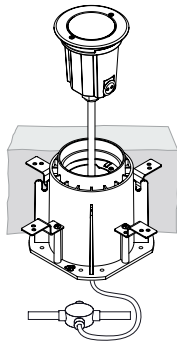

**Flexible Cable**

For connections to the branch circuit via junction box (by others) or other approved method. 6.5' (2 m) length. For other length options, contact Lumascape.

**Connection type '82'**  
North American market only

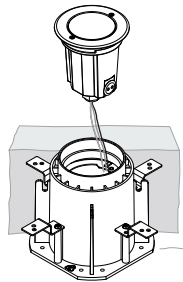

**1/2" NPT Adapter**

The luminaire is factory-fitted with 6.5' (2 m) hookup wire. Ensure terminations can be made within this length. For other length options, consult Lumascape.

**Round Flush Cover**

Flush covers for pre-installation, use special seals and support bushes to ensure static loads up to 6,614 lb (3,000 kg) are properly supported. In order, to achieve this drive-over rating, OptiClear™ or GripGlass™ must be used.



**Pre-Installation Blockout & Conduit Mount Round Flush Cover**  
■ SS316: Electro Polished



**Pre-Installation Blockout & Conduit Mount Round Flush Cover**  
■ Brass: Tumbled



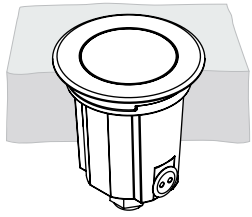

**Direct Burial**

Luminaire is put directly into soil or concrete.

<b>Used for</b>	Landscaping areas Applications where depth is restricted Rate for use in concrete pour applications Economical option
<b>Benefits</b>	Allows for maximum heat dissipation
<b>Restrictions</b>	Not as easy to remove for service as pre-install version Not suitable for drive-over (requires pre-installation) Connection Type 82 only available for North American market.

**Connection type '84'**

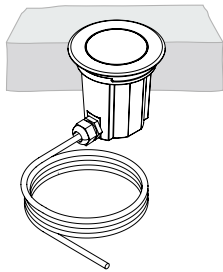

**Flexible Cable**

For connections to the branch circuit via junction box (by others) or other approved method. 6.5' (2 m) length. For other length options, contact Lumascape.

**Connection type '82'**  
North American Market only

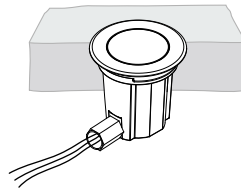

**1/2" NPT Adapter**

The luminaire is factory-fitted with 6.5' (2 m) hookup wire. Ensure terminations can be made within this length. For other length options, contact Lumascape.

**Round Flush Cover**

Use flush covers for installation in fine finished surfaces such as granite and marble. Can also be used in some suspended applications to conceal gaps between the luminaire and the surrounding surface.



**Round Flush Cover**  
■ SS316: Electro Polished



**Round Flush Cover**  
■ Brass: Tumbled



Network Topology - Line Voltage 220 to 240 Vac, 120/277 Vac Non-Dimmable

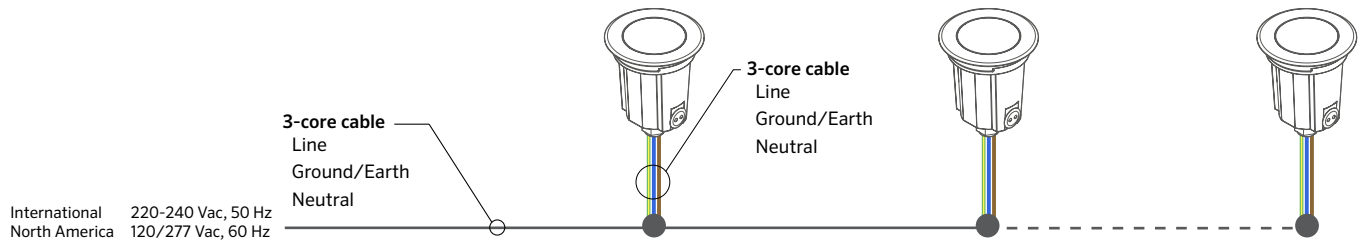

Network Topology - Line Voltage 220 to 240 Vac DALI

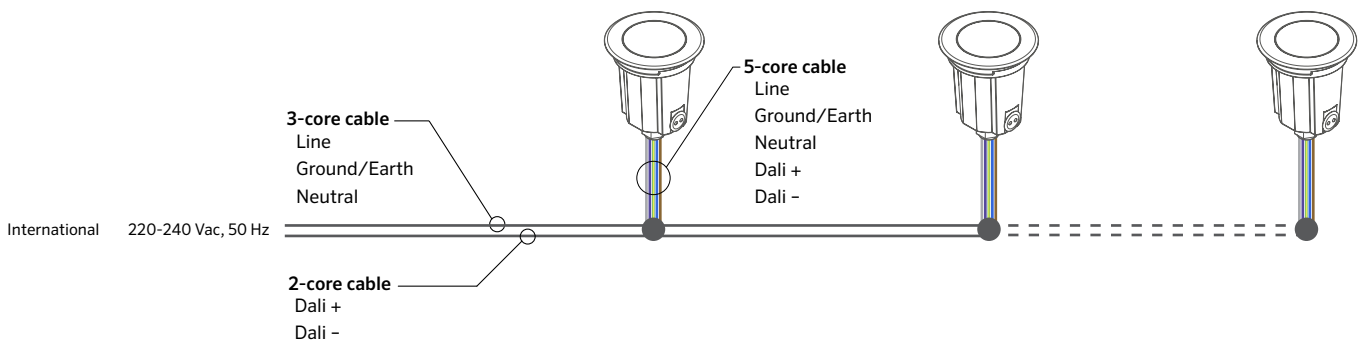

Network Topology - Low Voltage 24 Vdc, Non-Dimmable

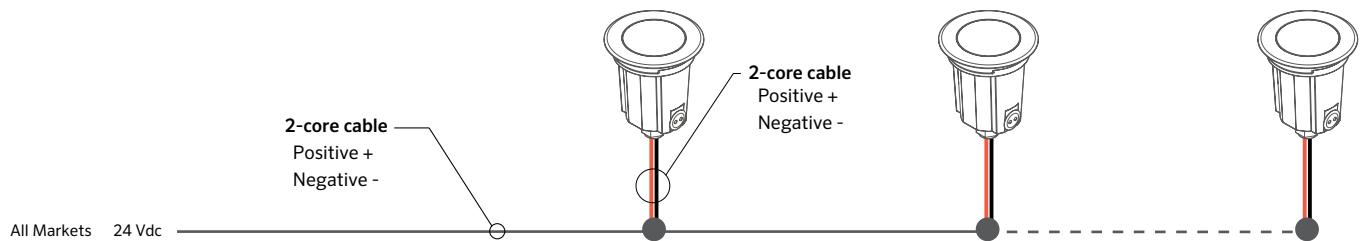

- Refer to "Transformer Compatibility Table", for maximum number of luminaires
- Calculations based on 14 AWG (2.5 mm<sup>2</sup>) trunk cable, and 16' (5 m) trunk cable between luminaires.
- Always observe local electrical codes for branch circuit current limitations
- For other configurations, contact Lumascape.

Transformer Compatibility Table

Supply Voltage	Luminaire Power	Max. Leader Cable Length from Power Supply to First Luminaire	Maximum Number of Luminaires per Power Supply				
			120 W	240 W	320 W	480 W	600 W
24 Vdc	5 W	50' (15 m)	16	17	17	17	17
		98' (30 m)	14	15	15	15	15
		164' (50 m)	12	12	12	12	12

Luminaire Wire Colors & Designations

Non-Dimmable Line Voltage 220-240 Vac - International

Designation	Color
Line	Brown
Neutral	Blue
Ground/Earth	Green / Yellow

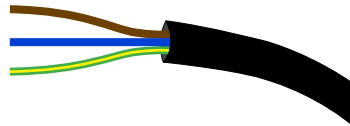

DALI Line Voltage 220-240 Vac - International

Designation	Color
Line	Brown
Neutral	Blue
Ground/Earth	Green / Yellow
DALI +	Grey
DALI -	Black



Non-Dimmable Line Voltage 120 Vac - North America

Designation	Color
Line	Black
Neutral	White
Ground/Earth	Green / Yellow

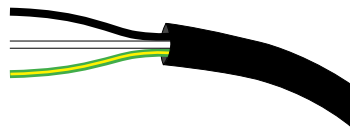

Low Voltage 24 Vdc

Designation	Color
Positive	Red
Negative	Black

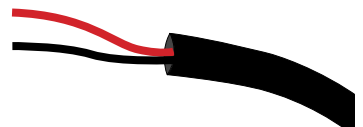

Accessories

Pre-Installation Kit

This type of installation requires the LS6388 Pre-Installation Kit (ordered separately), which acts as a concrete blockout and is intended for installation before the luminaire. This method ensures the luminaire itself is not damaged during concreting or other site works.



Product	Code
Pre-Installation Kit	LS6388

External Glare Shield

Integration of the LS6265 is supported only in pre-install configurations.

Product	Code	Installation Type	Code	Finish	Code
External Glare Shield	LS6265	Pre-Install Blockout	23	Tumbled Brass	TB

