



SECTION A

INSTALLATION INSTRUCTIONS
PRE - INSTALLATION BLOCKOUT



LS3150 GEN 2 Linear Inground Luminaire

READ ALL SAFETY INSTRUCTIONS FIRST

- › Follow instructions carefully, failure to do so will void warranty.
- › Ensure installation complies with local law and applicable standards.
- › Input voltage range 120-277 V
- › Only use Lumascape power supply, control equipment and leader cables.
- › Ensure mains input power is surge protected.
- › Never make connections whilst the power is connected.
- › Do not make modifications or alter the product.
- › Keep luminaire clean and free of debris.
- › Connectors are to be kept clean and dry at all times.
- › Once installed, all connectors are to be mated and a terminating plug is required on the last fitting of run.

Component Overview

Below is an exploded view of the pre-installation kit for the TE5 Terraluz Generation 2 linear inground luminaire. The diagram shows all of the components used in a typical pre-installation setup.

As a general rule one Bottom Plate (B), two Side Plates (A) and a Top Cover (C) are combined to build a segment. A single segment is a foot long and will be of sufficient length to accommodate a one foot luminaire. Finished segments are combined to cater for two, three and four foot luminaires. Section Joiners (E) are used to join adjacent sections. Section lengths must match luminaire lengths.

End Caps (D) are required for each end of a 'stand alone' section, as well as each 'end to end' section. A Small Top Cover (F) and a Small Bottom Plate (G) are needed to seal the end cap above and below; this is referred to as an end cap assembly.

Plastic parts will have a letter moulded into the part to help with assembly instruction and part identification on site.

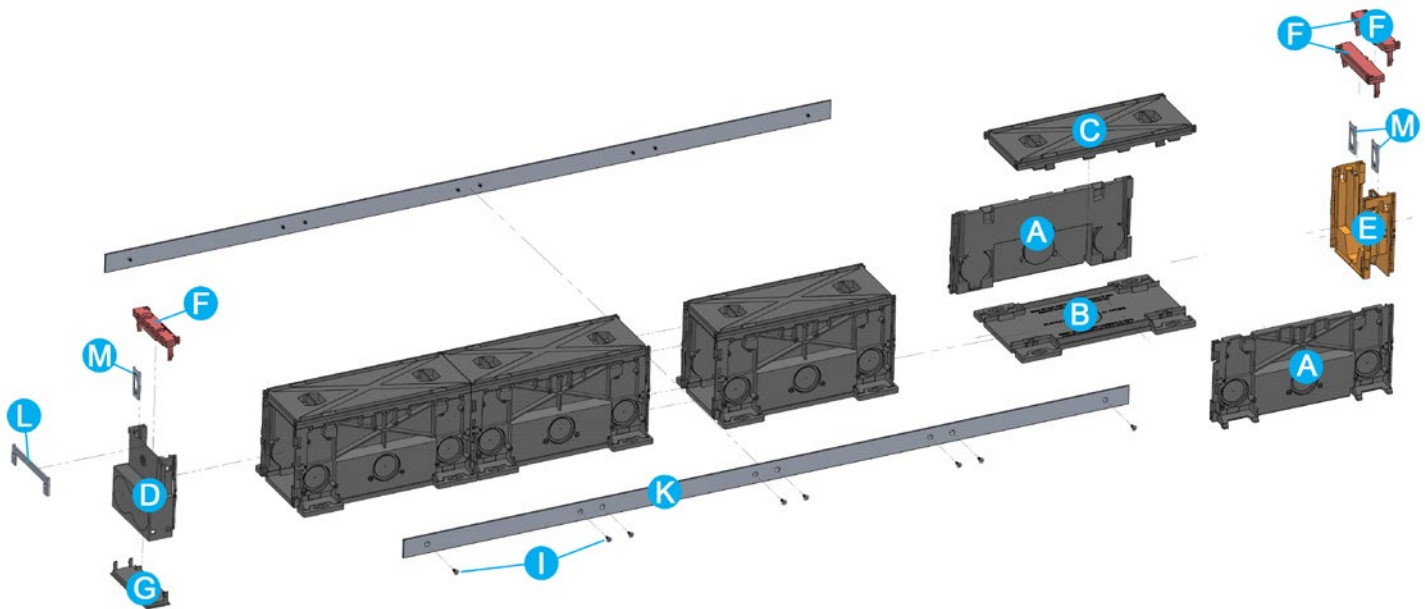

A	Side Plate	RM4792	I	SS Screw	RM4727
B	Bottom Plate	RM4792	K	SS Trim - 1ft	RM4699-A
C	Top Cover	RM4793		SS Trim - 2ft	RM4699-B
D	End Cap	RM4696		SS Trim - 3ft	RM4699-C
E	Section Joiner	RM4705		SS Trim - 4ft	RM4699-D
F	Small Top Cover	RM4795	L	SS Trim Endcap	RM4698
G	Small Bottom Plate	RM4843	M	Spring Clip	RM4709

Configurations

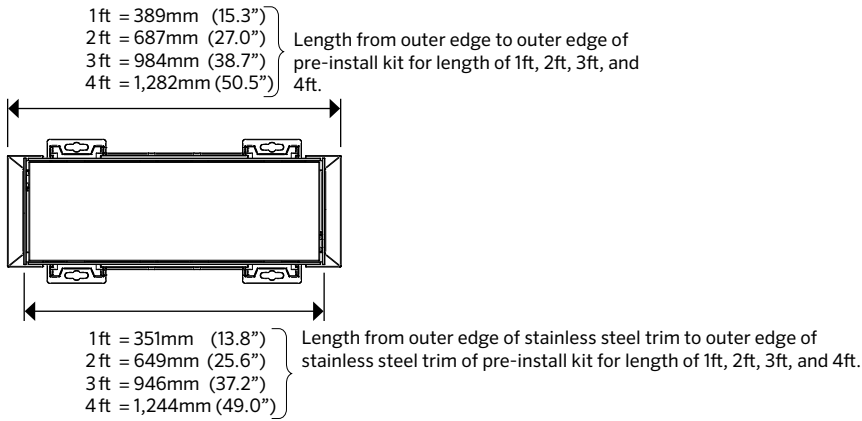

End to End Configuration

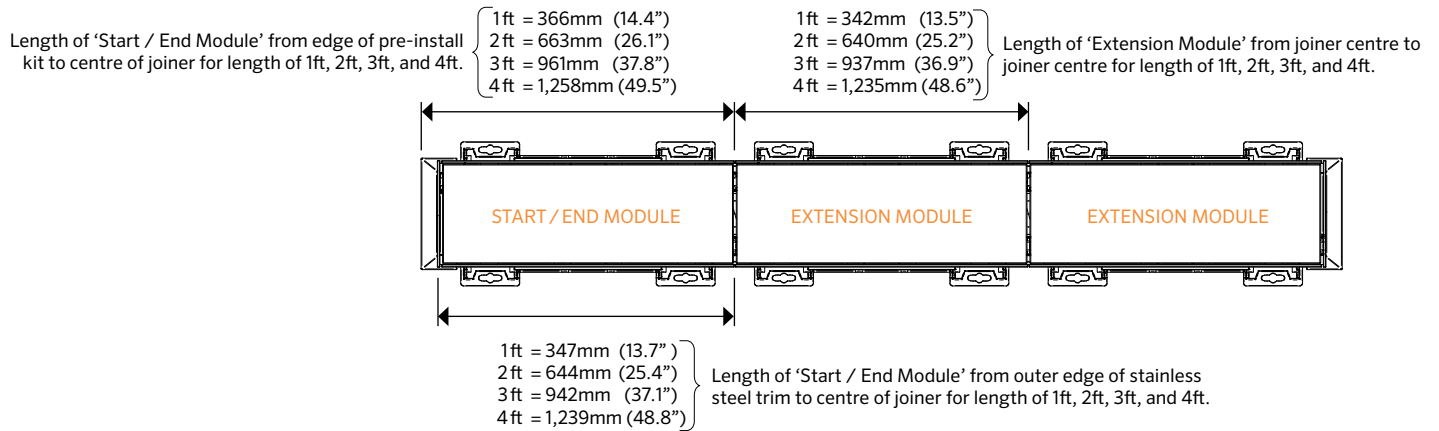

Configurations with Jumper Cables

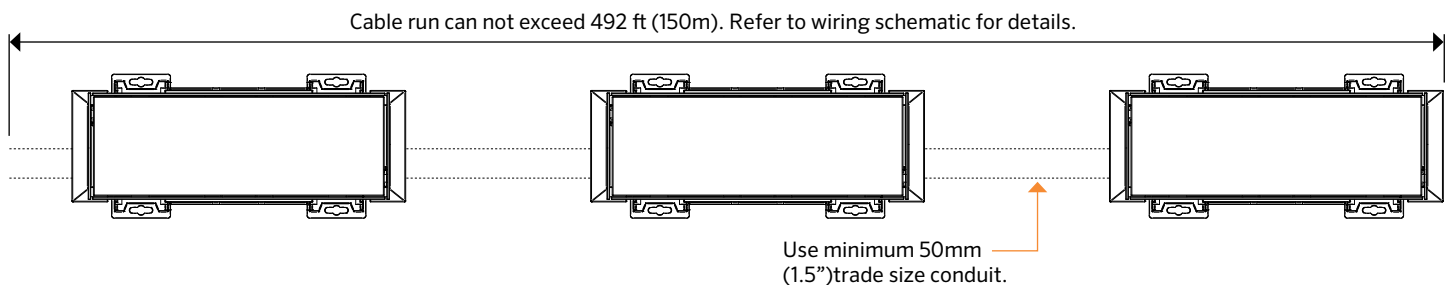

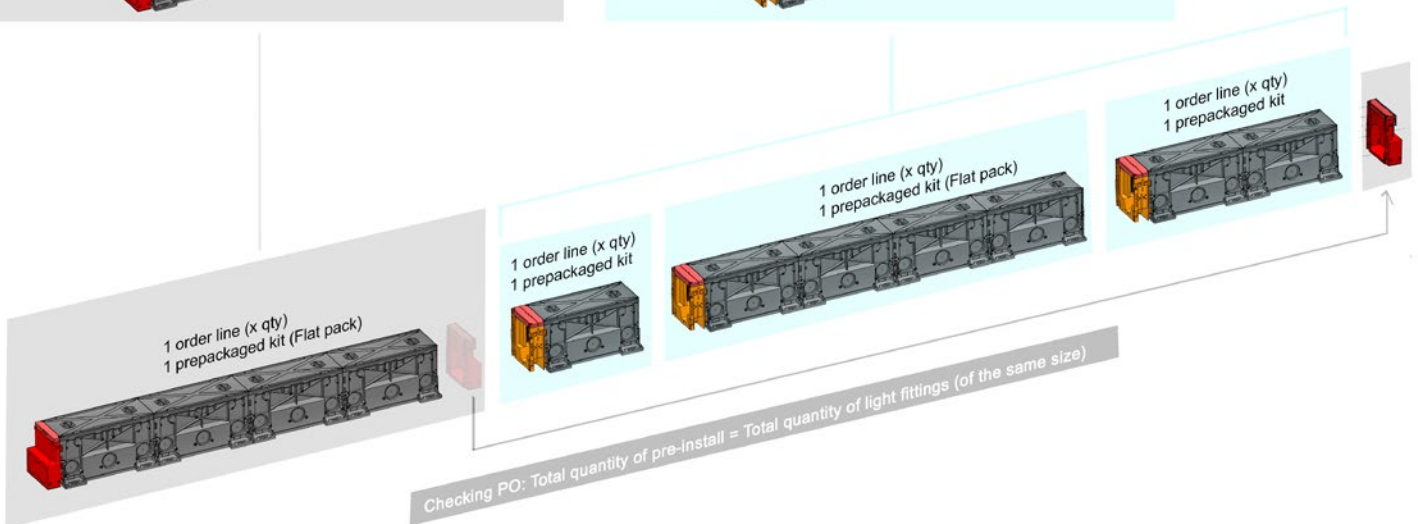
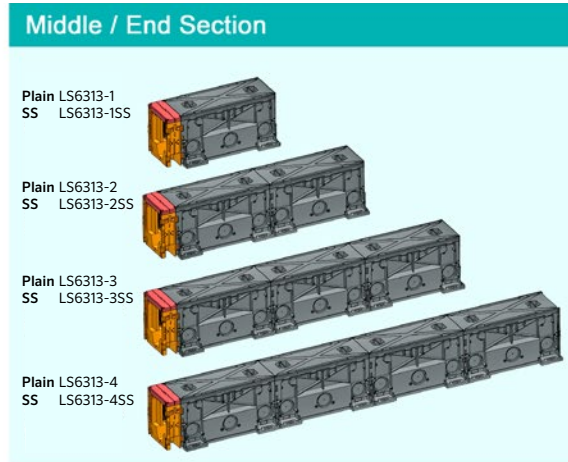
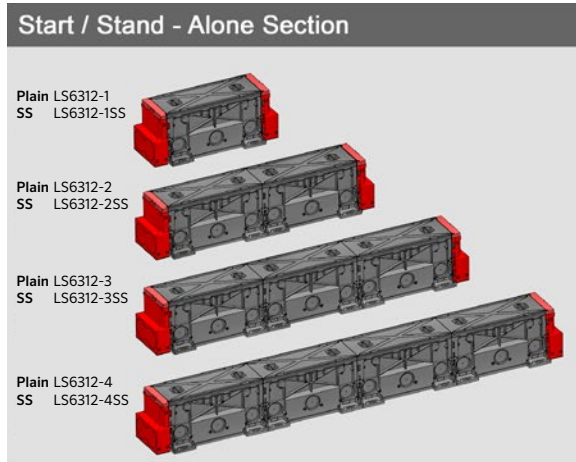

Drainage Requirements and Other Restrictions



Paver/Stonework

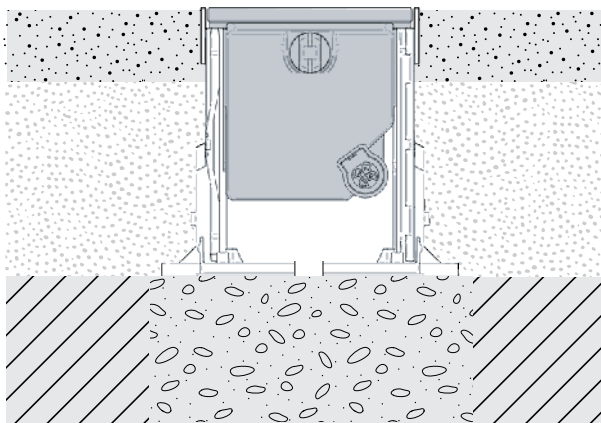

3/4" hole, minimum 1 per
4' (cut on site)

Above Waterproofing

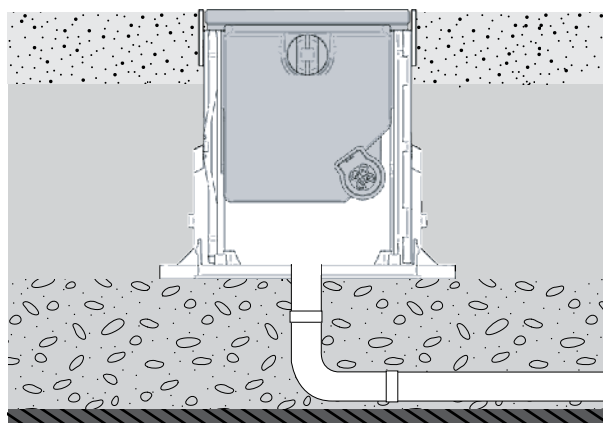

Piped draining required for locations not able to freely drain through
gravel (above waterproofing, clay base, etc).

Important Information

- Fill luminaire block-out with water to test drainage effects. Water must drain entirely.
- To prevent water accumulation, do not install at a location where site is hollow.
- Do not use fertilizer or corrosive chemicals adjacent to luminaire.
- Not suitable for drive-over.

Drainage Requirements and Other Restrictions

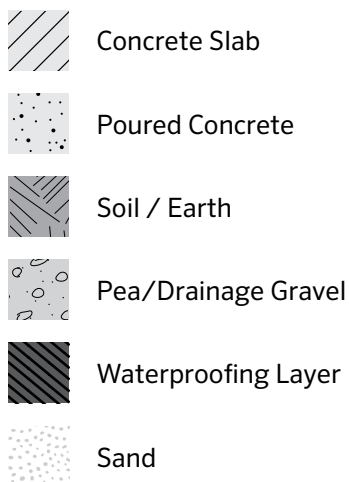

Landscape/Softscape

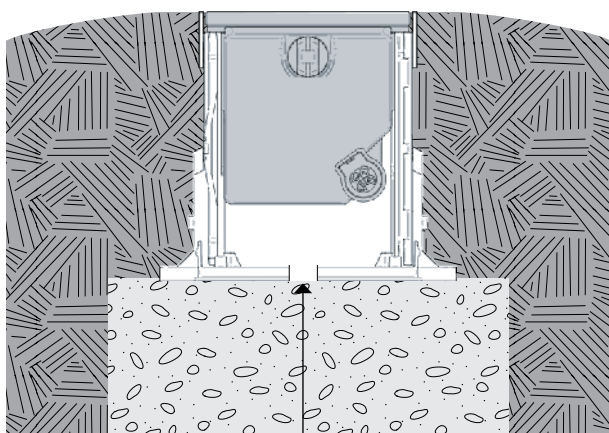

3/4" hole, minimum 1 per
4' (cut on site)

Concrete

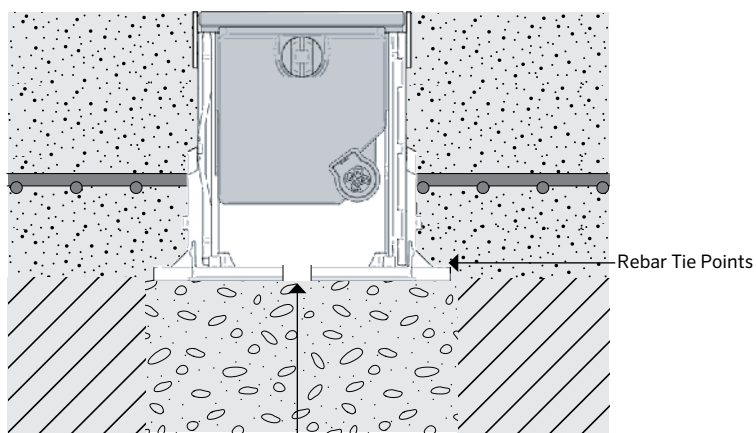

3/4" hole, minimum 1 per
4' (cut on site)

Rebar Tie Points

Important Information

- Fill luminaire block-out with water to test drainage effects. Water must drain entirely.
- To prevent water accumulation, do not install at a location where site is hollow.
- Do not use fertilizer or corrosive chemicals adjacent to luminaire.
- Not suitable for drive-over.



Building Channels

Step 1 Place the base plate (B) flat on the ground.



Step 2 Insert feet of side plate (A) into base plate (B) and rotate until the part snaps into place.



Step 3 Repeat previous step on opposite side.



Step 4 You have now constructed a complete 1ft channel.



Step 5 Slide 1ft channels together to built 2ft, 3ft and 4ft pre-installation channels. Section lengths must match ordered fixture lengths.

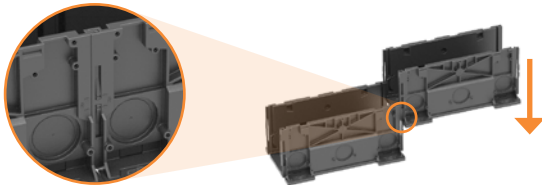

Step 6 Channels for 1ft, 2ft, 3ft and 4ft luminaires.

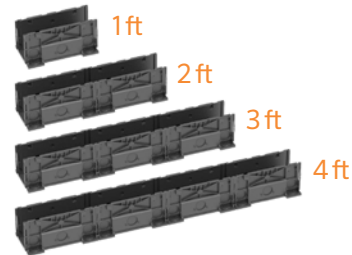

Step 7 Complete the section with an end cap on one side and a section joiner or and end cap on the other side.

Section Joiner

Use to add a channel for another luminaire

End Cap

Use to start and end stand-alone sections and continuous runs.

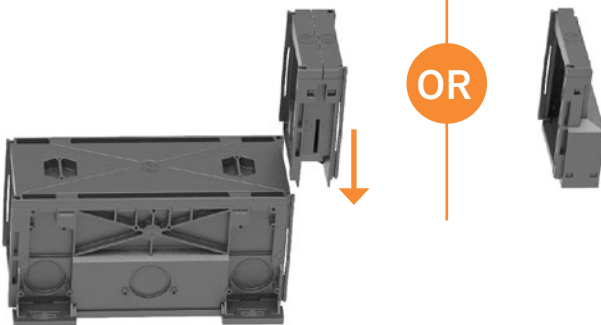

Installing Stainless Steel Trim (SS Kits Only)

Install the stainless steel trim on all sides. Trim is shipped as a 1ft, 2ft, 3ft and 4ft strips to suit luminaires and channels built.

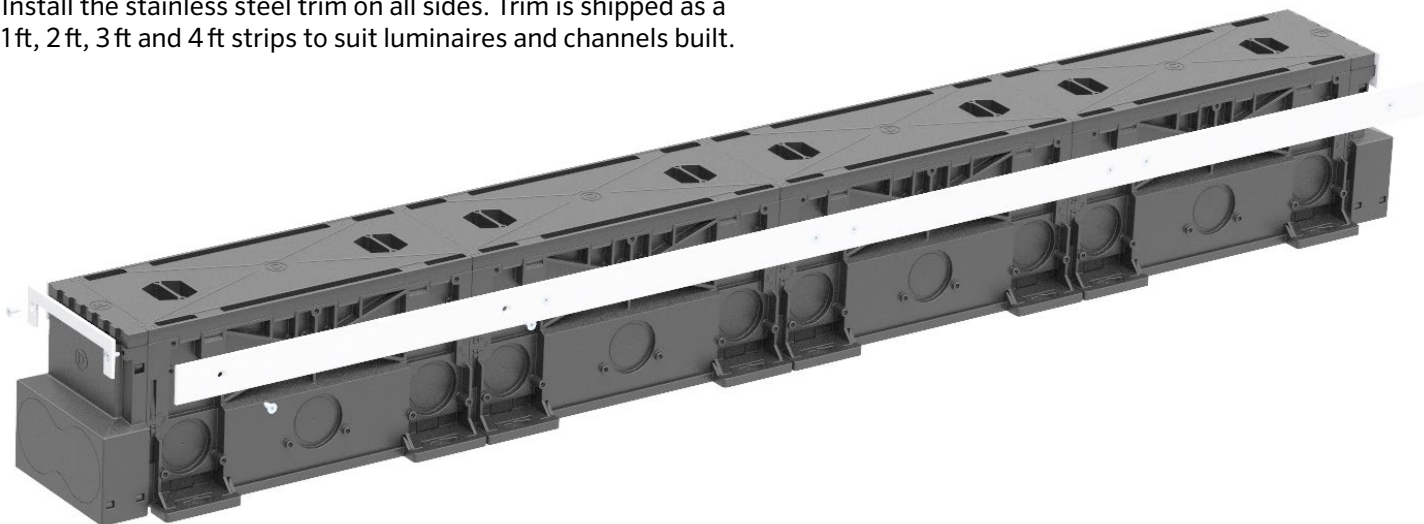

Drainage Requirements

Step 1 Use a hole saw to drill out a hole and allow access for a drain pipe.

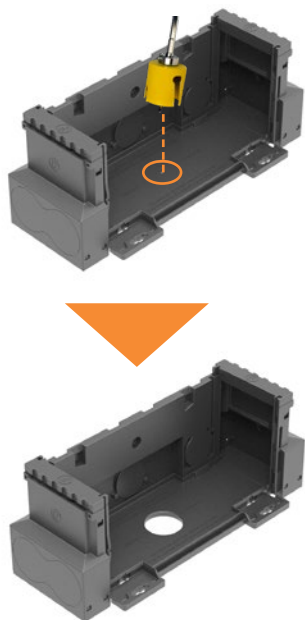

Step 2 Connect the pre-installation channel to the drain pipe and seal with silicone.

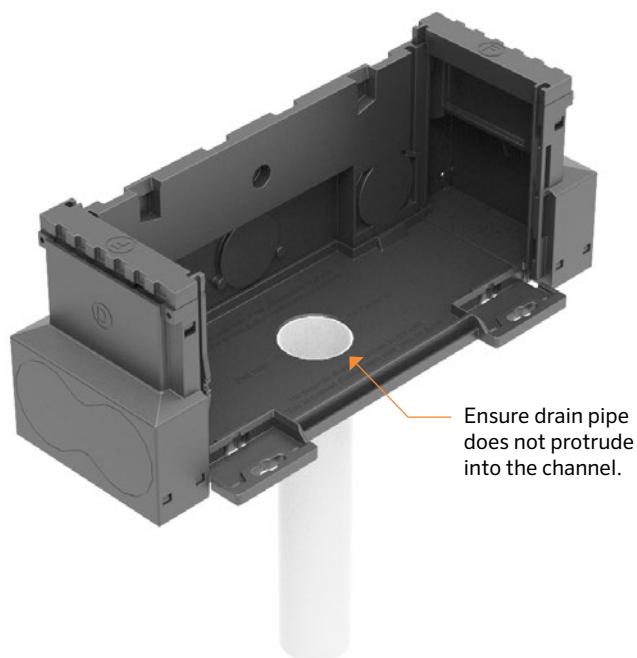

Install Electrical Conduit

Step 1 Use a hole saw to drill out a hole and allow access for the electrical conduit.

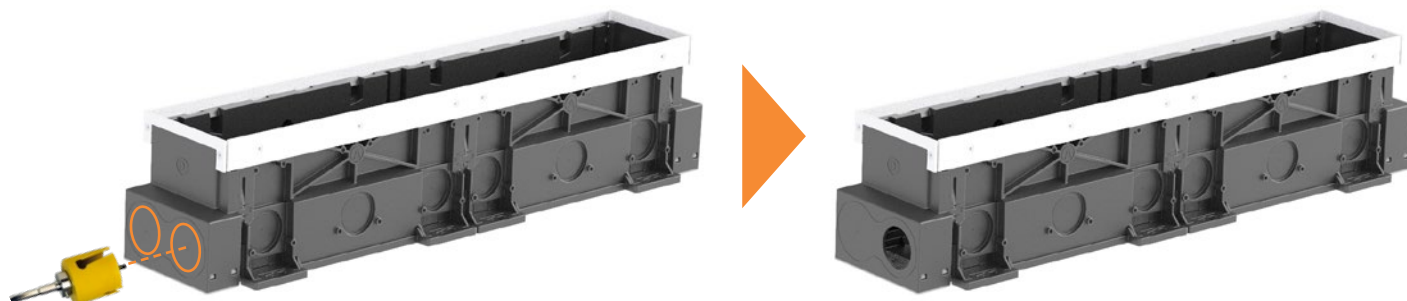

	Trade Size Clearance w/o connector	Trade Size Clearance with connector
North America	0.75"	1.5"
EMEA	25 mm	50 mm

Step 2 Connect the electrical conduit to the pre-installation channel and seal with silicone as required. Note: Leader cable ships with connector attached. It is recommended to feed the leader cable through the conduit from the luminaire end.

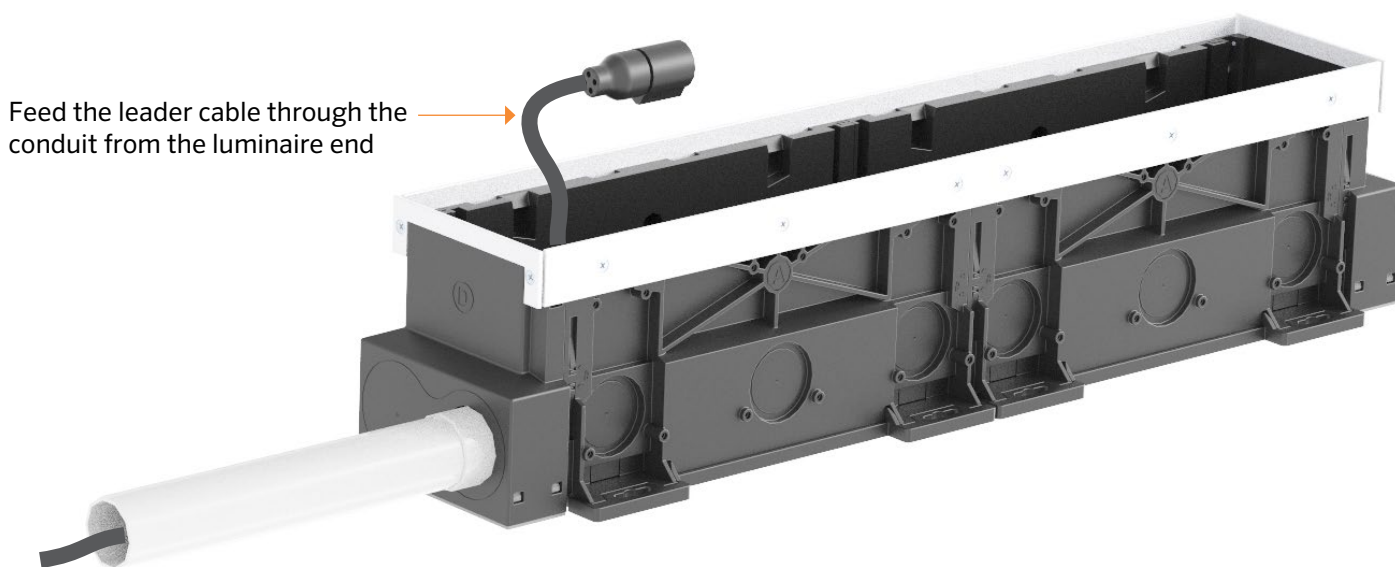

Install Luminaire

Step 1 Your assembled pre-install kit has been placed in the ground, drainage and a supply have been connected and concrete has been poured.

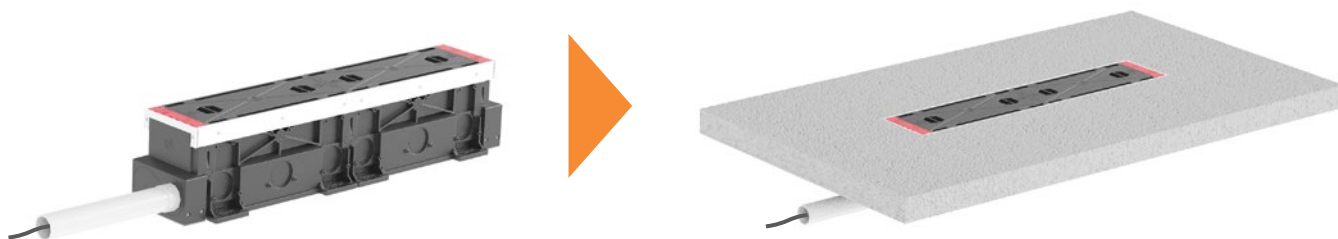

Step 2 Remove the temporary covers from the pre-install kit. Make sure you do not forget the small covers in the end. Covers are recyclable and should be kept for client maintenance purposes.

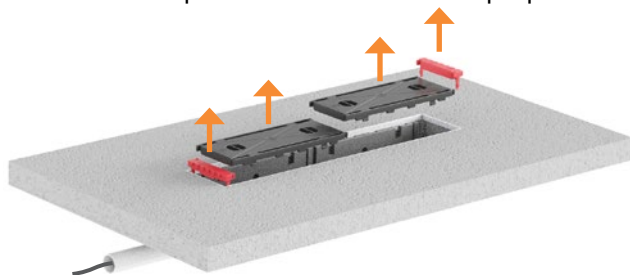

Step 3 Find the supply cable to connect the luminaire.

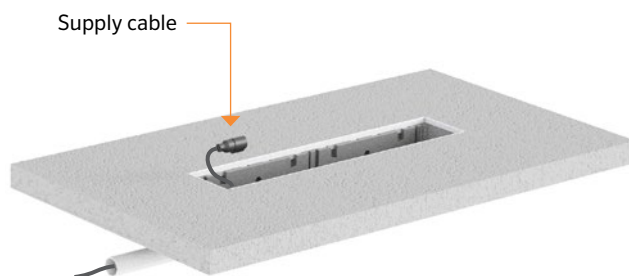

Step 4 Connect luminaire to supply cable and either loop through to next luminaire or terminate the luminaire run. Drop the luminaire into the pre-install kit. The luminaire can be rotated by 180° around the vertical axis if required.

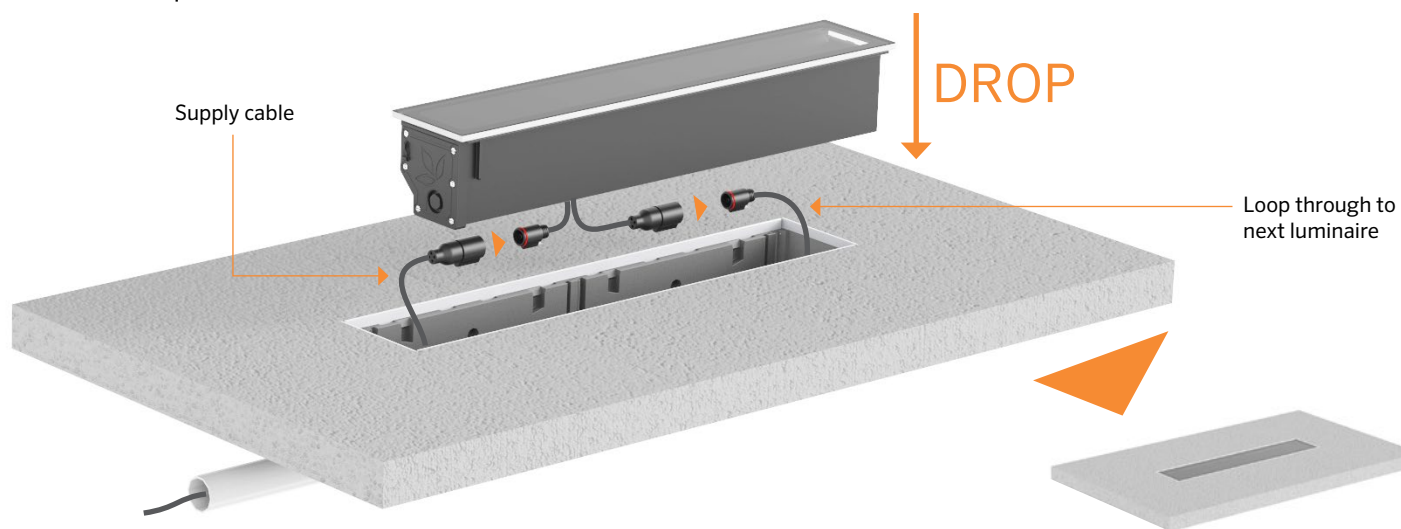

Luminaire Removal

Step 1 Insert the multi tool at edge of the luminaire between the luminaire and the pre-install kit.

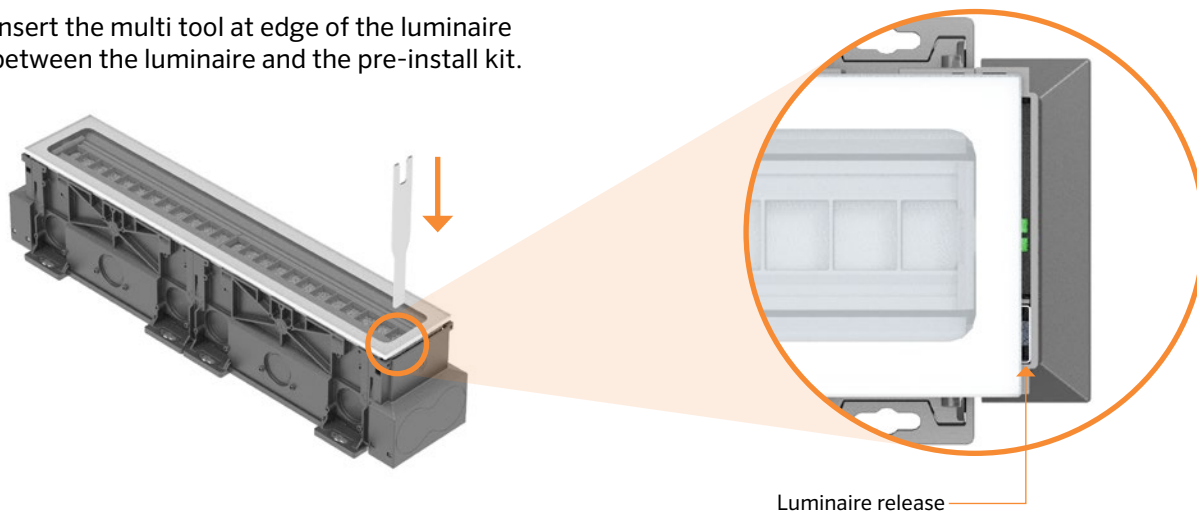

Step 2 Push down and the luminaire will release. With the tool still in place lift out the luminaire on the one side. Support the removed luminaire and remove the tool. Letting the luminaire slip back into the pre-install kit will lock it back into place.

Step 3 Repeat the process diagonally across on the other side and pull out the luminaire. To completely remove the luminaire you will have to disconnect the cables. One of the connections is located beneath the adjacent luminaire. For larger luminaires, suction cups can be used to aid the removal process.

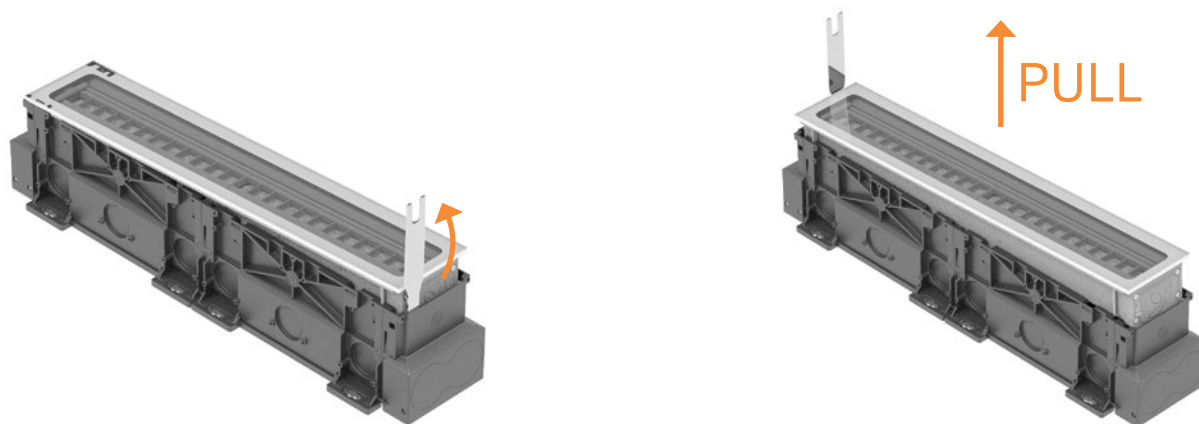

IMPORTANT: If the luminaire is to be removed, ensure a jumper cable is available to bridge the circuit, and the temporary covers are re-installed to cover the hole.

Adjust Optical System Tilt

Step 1 Insert the multi tool on centre edge of the luminaire between the luminaire and the pre-install kit.

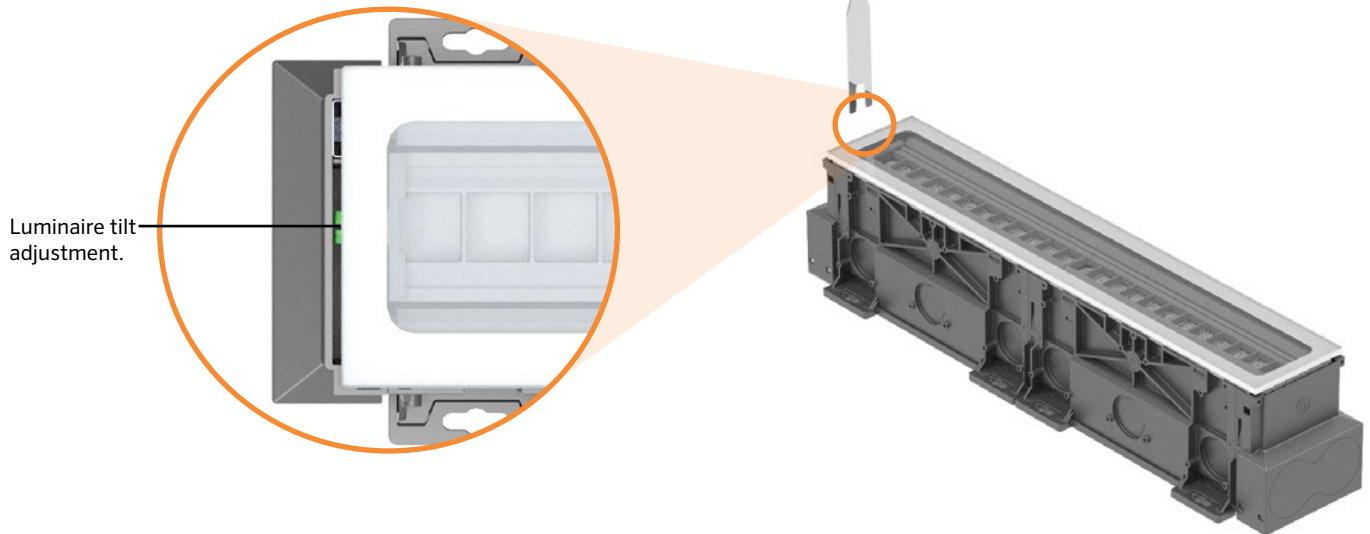

Step 2 Rotate to adjust luminaire tilt.

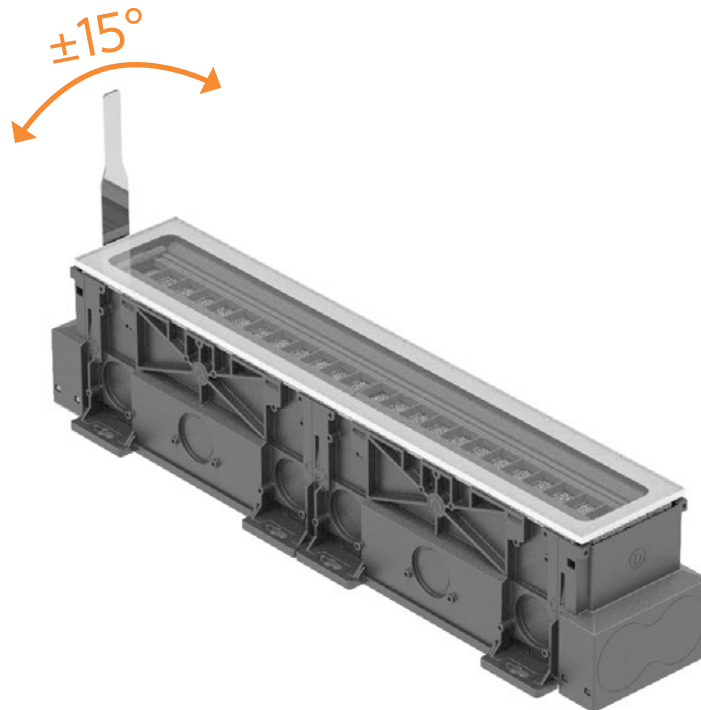

Network Topology

PowerSync™ Topology 1 - Single Trunk Cable

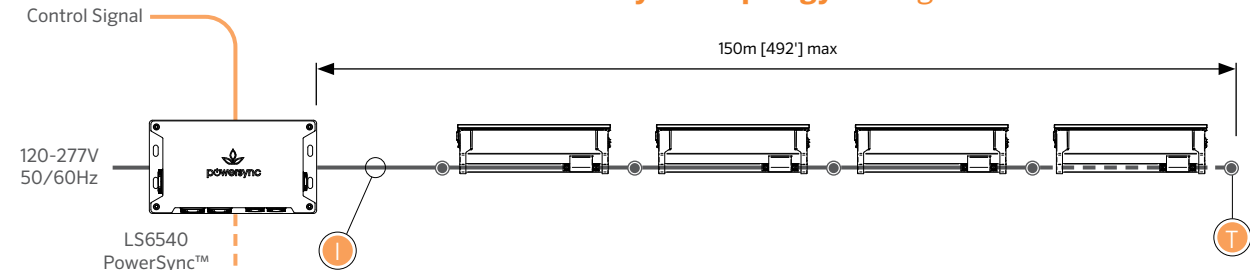

PowerSync™ Topology 2 - Split Trunk Cable

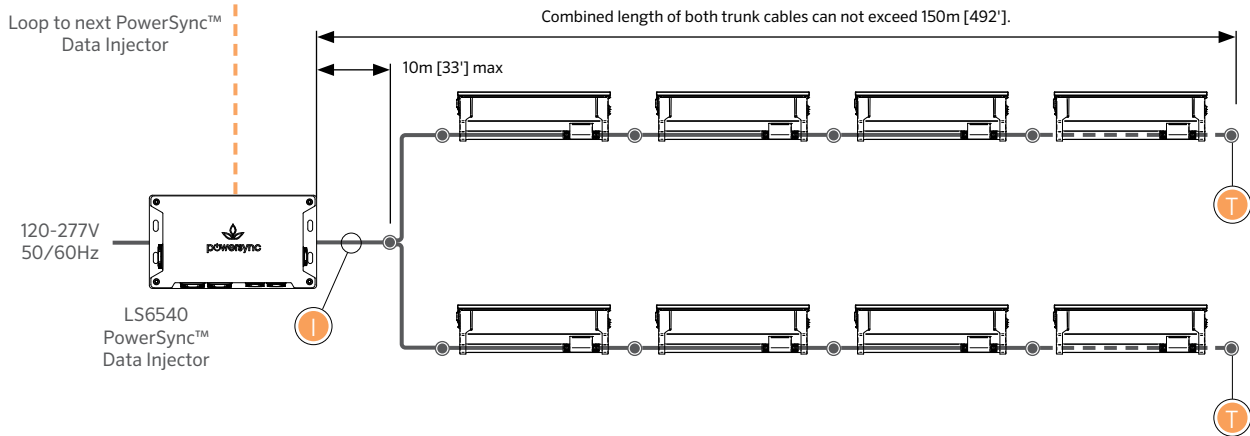

Up to 45 luminaires per run under the following conditions:

- e Max total cable run length 150m (492') in up to two trunk cables
- e For run lengths in excess of 30m (100'), the data wire gauge cannot exceed 14 AWG (2.5mm²)
- e For run lengths up to 30m (100'), the data wire gauge is not governed
- e Refer to 'Max Circuit Load' table for circuit limitations
- e Always observe local electrical codes for branch circuit current limitations

T Terminator
Use PowerSync™ terminator, supplied with leader cable to terminate last luminaire in chain.

I Maximum Current
≤16.0A - International market
≤12.8A - North American market

● Connection Type
Circuits can be configured as either connectorised or hardwired. For details consult installation instructions and comply with local electrical codes.

Maximum Circuit Load

Maximum Number of Interconnected Fixtures		120V		240V		277V	
Luminaire Length	LED Power	12.8A	16A	12.8A	16A	12.8A	16A
1ft	16W	45	45	45	45	45	45
2ft	16W	40	45	45	45	45	45
3ft	16W	26	35	45	45	45	45
4ft	16W	20	26	40	45	45	45

Refer to PowerSync™ installation manual for maximum distance information and topology options.
All connectorised options in North America are limited to 12.8A branch circuit load.
For non-continuous runs contact factory for details.



Network Topology - Non-Dimmable

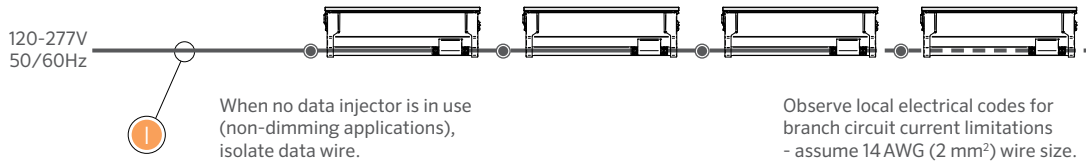

Up to 45 luminaires per run under the following conditions:

- e Max total cable run length 150m (492') in up to two trunk cables
- e For run lengths in excess of 30m (100'), the data wire gauge cannot exceed 14 AWG (2.5mm²)
- e For run lengths up to 30m (100'), the data wire gauge is not governed
- e Refer to 'Max Circuit Load' table for circuit limitations
- e Always observe local electrical codes for branch circuit current limitations



Terminator

Use PowerSync™ terminator, supplied with leader cable to terminate last luminaire in chain.



Maximum Current

≤16.0A - International market
≤12.8A - North American market



Connection Type

Circuits can be configured as either connectorised or hardwired. For details consult installation instructions and comply with local electrical codes.

Maximum Circuit Load

Maximum Number of Interconnected Fixtures							
Luminaire Length	LED Power	120V		240V		277V	
		12.8A	16A	12.8A	16A	12.8A	16A
1ft	16W	45	45	45	45	45	45
2ft	16W	40	45	45	45	45	45
3ft	16W	26	35	45	45	45	45
4ft	16W	20	26	40	45	45	45

Refer to PowerSync™ installation manual for maximum distance information and typology options.
All connectorised options in North America are limited to 12.8A branch circuit load.
For non-continuous runs contact factory for details.