

Warranty Void if not installed as per installation instructions and in compliance with the local electrical code.

READ ALL SAFETY INSTRUCTIONS FIRST

- › Follow instructions carefully, failure to do so will void warranty.
- › Ensure installation complies with local law and applicable standards.
- › Input voltage range:
 - International: 220-240 V AC 50/60Hz
 - North America: 120/277 V AC 60Hz
 - All Markets: 30-48 VDC
- › Requires Lumascope PowerSync Master for dimming or color changing:
 - LS6540 Mains Voltage
 - LS6550 Low Voltage
- › Never make connections whilst the power is connected.
- › All connections must be kept dry; failure to do so may result in product reliability issues.
- › Ensure mains input power is surge protected.
- › Do not make modifications or alter the product.
- › Keep luminaire clean and free of debris.

Products and specifications are subject to change without notice.
LS3080_PI_CO_IN0176_260526

General Assembly

 To prevent condensation, ensure luminaire is acclimatized (at same temperature as environment) before installation.

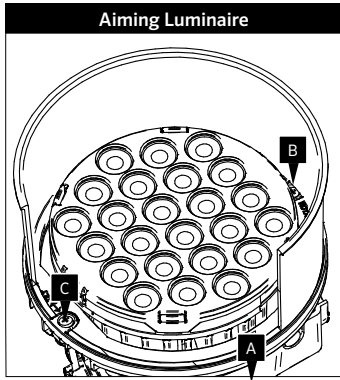

- A Aim Mark**
Point in the direction of the target to be lit.
- B Rotation Lock Screw**
Tighten to lock gimbal rotation.
- C Tilt Adjustment Screw**
Turn to adjust tilt of gimbal.

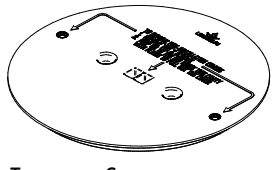

Temporary Cover
Keep on pre-installation kit in order to avoid concrete and debris from entering the cavity. Remove when ready to install luminaire.

Poured Concrete

Foam Plug
Use as a temporary barrier when concrete is poured around pre-installation kit. Remove before installing luminaire to allow for adequate drainage.

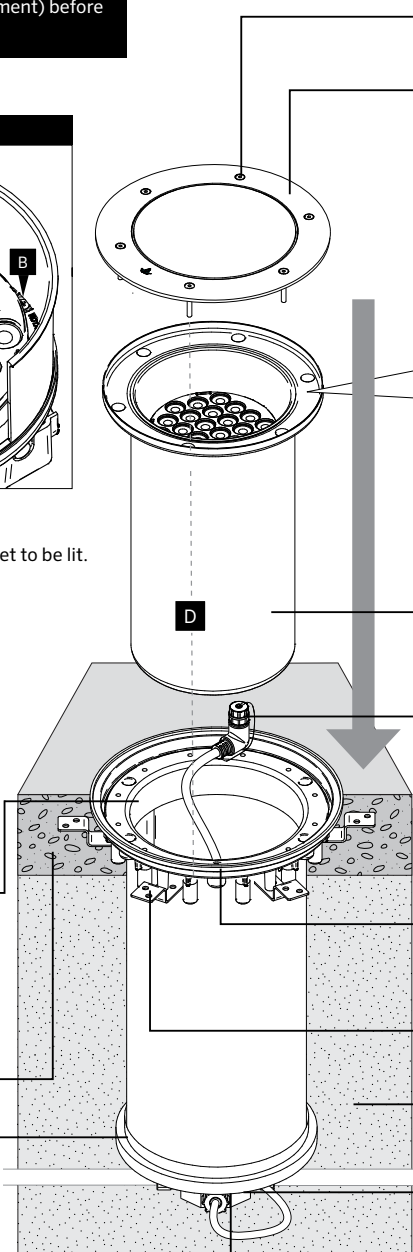

Cover Screw(s)
Tighten in the following torque pattern to seal luminaire.

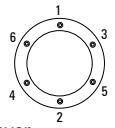

Luminaire Cover
After aiming luminaire at target seal luminaire using the cover. Align the cover screws and the screw holes in the luminaire body with the corresponding threaded holes in the pre-installation kit. Be sure to tighten cover screws as per the torque pattern shown above. **D**

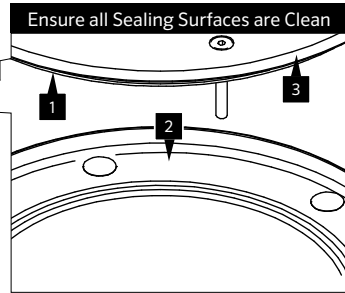

- Ensure all Sealing Surfaces are Clean**
Ensure all sealing surfaces are clean and free of concrete, dirt, debris or any other foreign matter. Sealing Surfaces include.
- 1** Entire Rubber Lid Seal
 - 2** Luminaire Flange
 - 3** Luminaire Lid Underside

Luminaire Body
Slide into pre-installation kit and secure to mounting collar using cover and cover screws.

IP68 Connector
Connect at base of luminaire. Ensure open connectors are kept clean and dry at all times.

Type	Use	Identification
85	Legacy Item	Yellow cable, 3 pin plug
87	For Single Color, Non-Dimming	Black cable, 3 pin plug
77	For all PowerSync™ applications	Black cable, 4+ pin plug

Mounting Collar
Ensure final installation surface is completely flush with top face of the blockout.

Mounting Brackets
Screw mounting brackets to collar to arrest any movement.

Gravel
Use gravel which allows good drainage around luminaire.

Junction Box & IP68 Connector
Connect in accordance to local wiring rules. Use gel filled wire nuts (included) or re-enterable epoxy resin to ensure electrical connections are protected from moisture.

Junction Box
Position to ensure accessibility.

WARNING

- › The luminaire should only be used complete with its protective shield (cover).
- › Keep electronics free from dirt and moisture.
- › Luminaires can become very hot. Use discretion in placement.
- › No power tools to be used.
- › Do not shorten or interfere with cable assembly.
- › Warranty will be void if cable assembly is tampered with.
- › Do not overtighten lid screws.
- › Do not apply downward force on the lid of luminaire.

Component Overview

Connection Type '77'

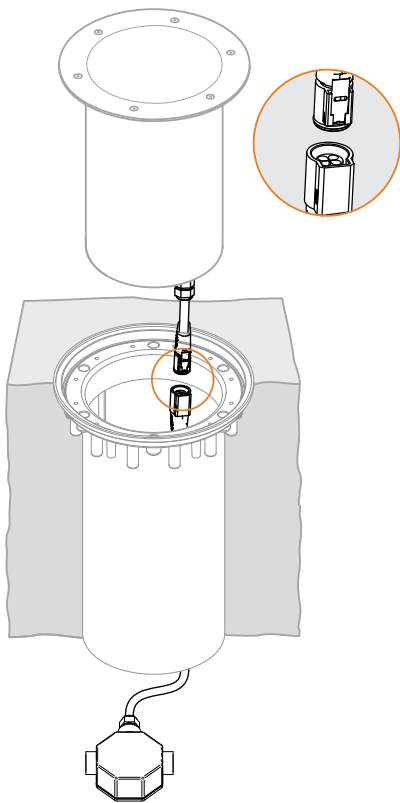

Type 77 must be fully inserted until lock clicks into place.

Connection Type '87'

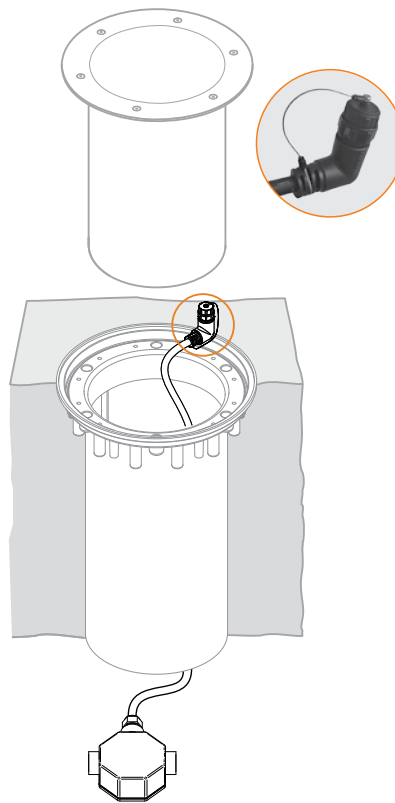

Type 87 is to be fully inserted and the retainer firmly tightened.

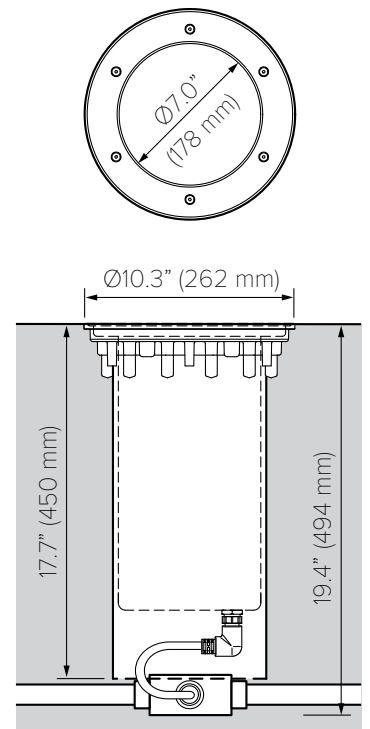

Ensure open connectors are kept clean and dry at all times.

Network Topology

Australia | Asia | Middle East | Europe

LS3080 Dimming - Mains Voltage

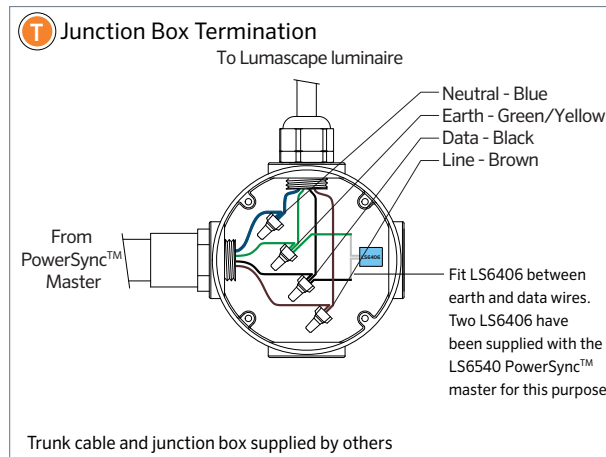
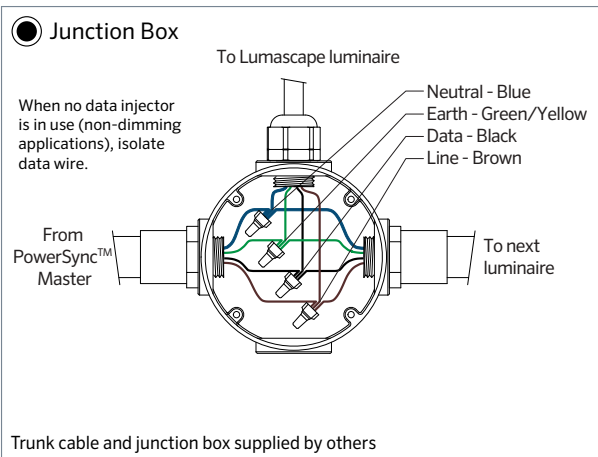
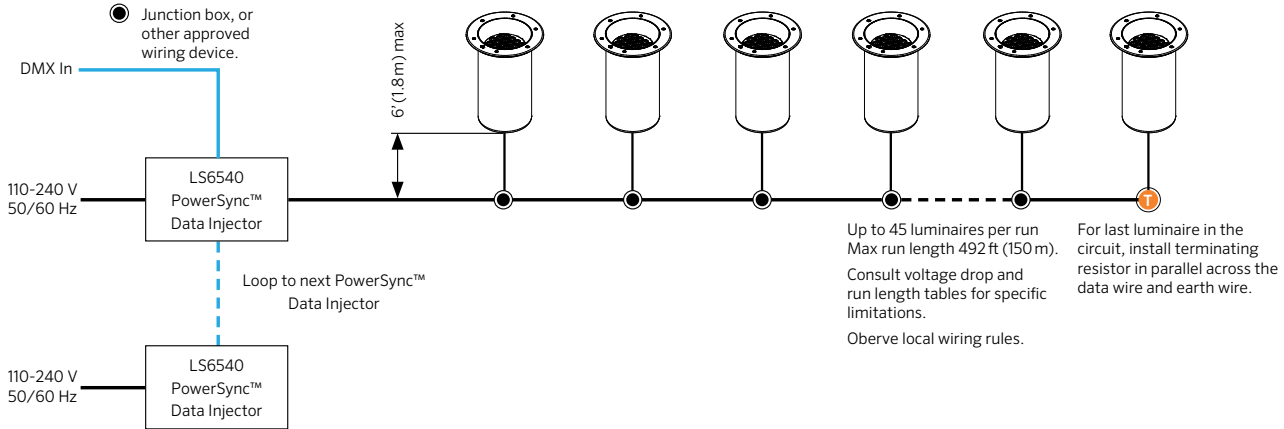

LS3080 Non-Dimming - Mains Voltage

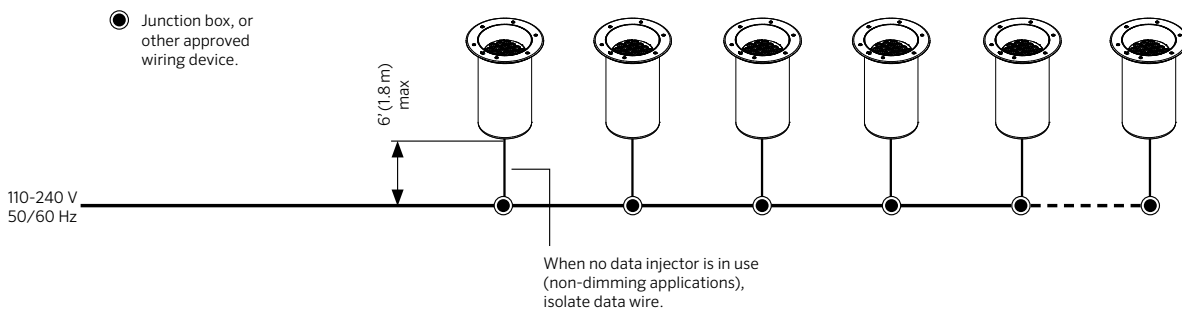

Network Topology

LS3080 Dimming - Mains Voltage

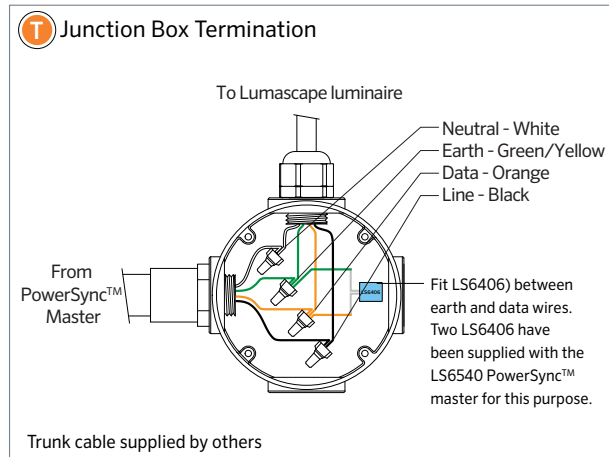
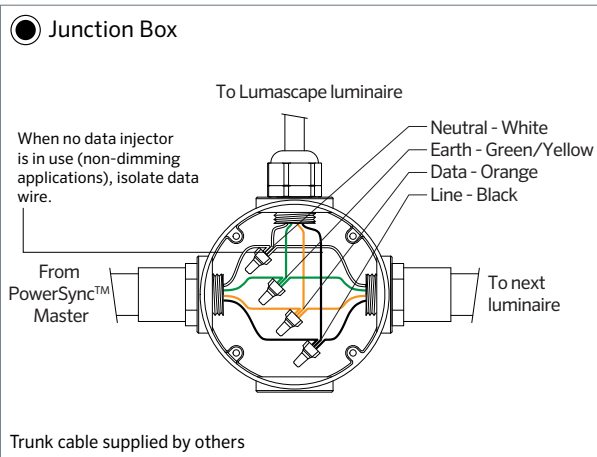
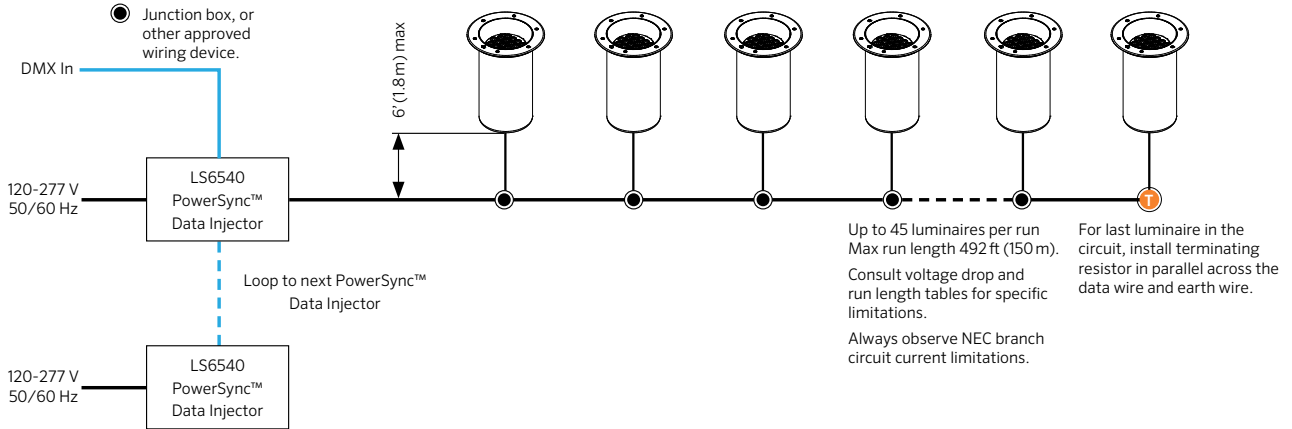

LS3080 Non-Dimming

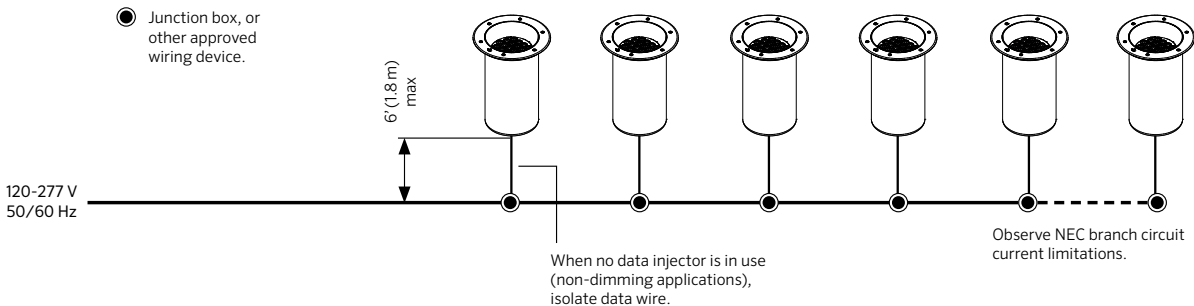

Network Topology

Australia | Asia | Middle East | Europe | North America

LS3080 Dimming - Low Voltage

Circuit Limits - Dimmable and Color-Changing via PowerSync™

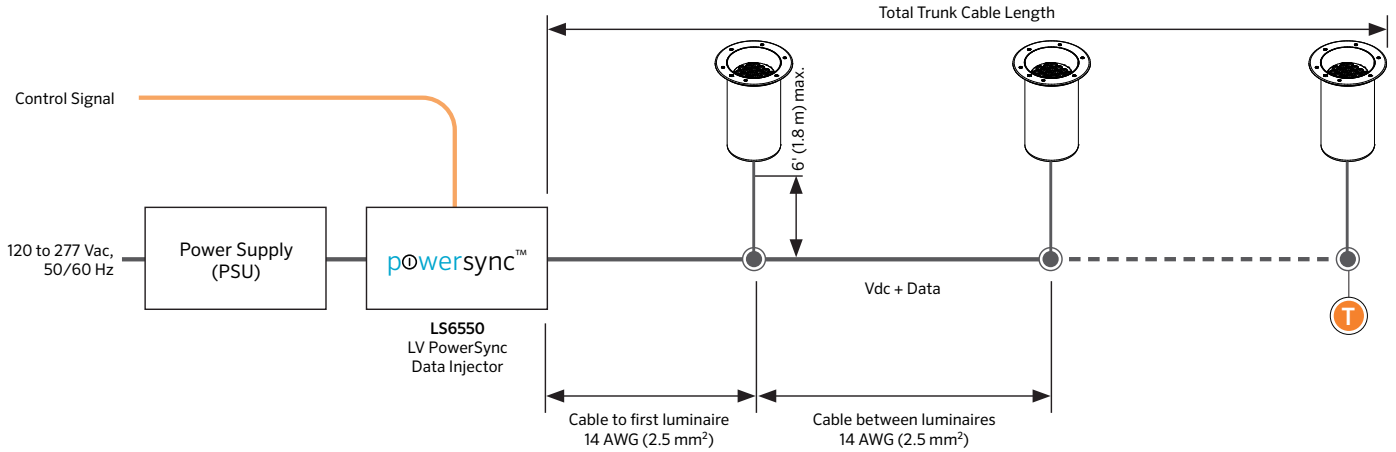

- Refer to "Transformer Compatibility Table", for maximum number of luminaires
- Calculations based on 14 AWG (2.5 mm²) trunk cable, and 16' (5 m) trunk cable between luminaires.
- Always observe local electrical codes for branch circuit current limitations
- For other configurations, contact Lumascape.

Transformer Compatibility Table

Supply Voltage	Luminaire Power	Max. Leader Cable Length from Power Supply to First Luminaire	Maximum Number of Luminaires per Power Supply				
			120 W	240 W	320 W	480 W	600 W
30 Vdc	40 W	50' (15 m)	-	-	-	-	-
		98' (30 m)	-	-	-	-	-
		164' (50 m)	-	-	-	-	-
48 Vdc	40 W	50' (15 m)	-	-	-	-	-
		98' (30 m)	-	-	-	-	-
		164' (50 m)	-	-	-	-	-



Terminator

Use PowerSync™ terminator, supplied with PowerSync Injector to terminate last luminaire in chain.

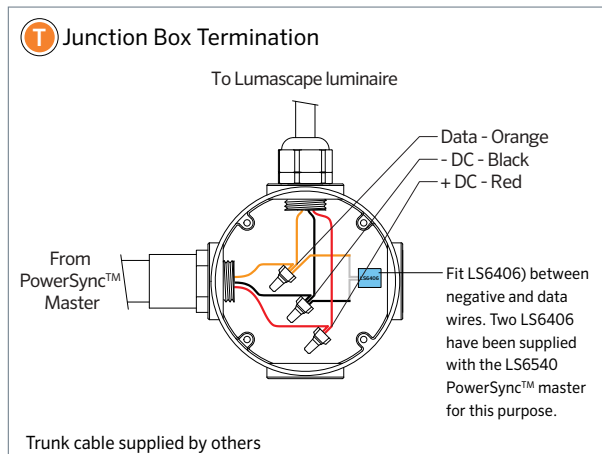
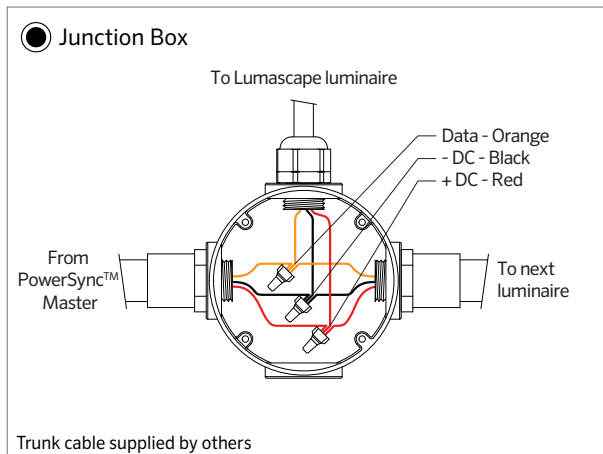

Installation

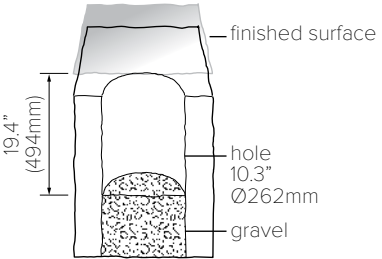
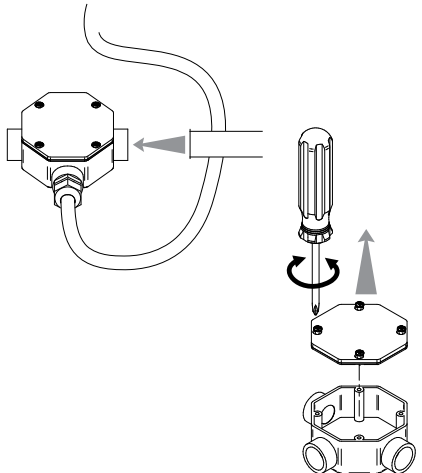
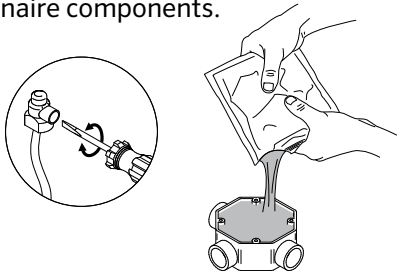
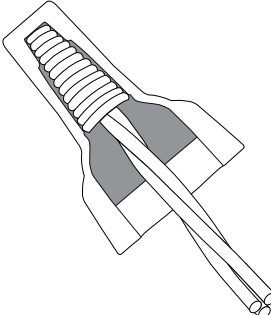
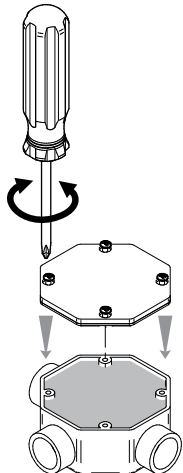
<p>Step 1</p> <p>Layout luminaire locations as required. Use discretion in placement as luminaire may become hot and could burn. Luminaire cavity should be as shown. Ensure gravel or similar medium forms the bottom of the cavity to allow drainage.</p> <p>Note: Always check luminaire lable for correct supply details and lamp type if applicable.</p> 	<p>Step 2</p> <p>Type 77 & 87 connection only</p> <ul style="list-style-type: none"> • Connect junction box and punch a hole in the foam plug to pass through connector. • Pack hole in plug around the cable to ensure concrete does not enter the luminaire cavity. <p>IMPORTANT: Ensure cap on the connector is secure.</p>	<p>Step 3</p> <p>Connect according to junction box installation instructions and local wiring rules.</p> 
<p>Step 4</p> <p>Connect wiring and test prior to potting. Add electrical grade epoxy resin to water proof junction box.</p> <p>IMPORTANT: Power supply must be isolated prior to connection or disconnection of cables. Failure to do so will result in damage to the luminaire components.</p>  <div data-bbox="95 1736 526 1848" style="border: 1px solid black; padding: 5px;"> <p>Epoxy sachet not supplied by Lumascape Use electrical grade epoxy to water proof electrical connection in junction box.</p> </div>	<p>Step 4A</p> <p>Alternatively, connect wiring using gel filled connectors.</p> <p>IMPORTANT: Power supply must be isolated prior to connection or disconnection of cables. Failure to do so will result in damage to the luminaire components.</p> 	<p>Step 5</p> <p>Using a screwdriver, seal junction box. Ensure not to overtighten.</p> 

Installation

Step 6

Position and use screws to attach brackets at the bottom of the mounting collar before concrete is poured.

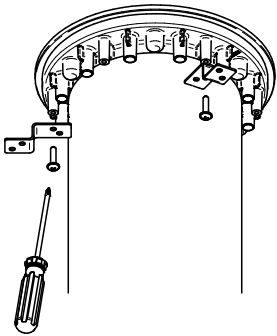

Step 7

Fit sleeve, collar and cover plate.

- Fit sleeve and collar over foam plug.
- Ensure enough cable is in the cavity to connect to luminaire.
- Position top surface of the mounting collar to be flush with final surface level.
- Screw cover plate to mounting collar.
- Ensure ample depth for fitting.

Step 8

Pour concrete. Check that the top surface of the mounting collar is flush with the finished surface level.

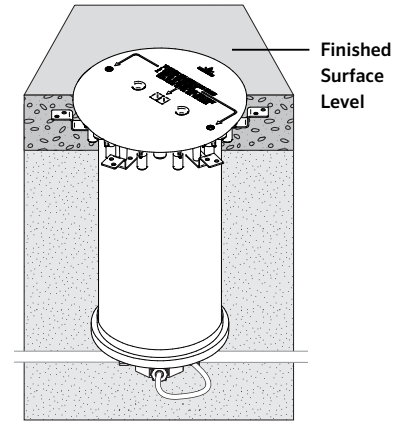

Where possible position j-box within void.

Step 9

When ready to install luminaire;

- Destroy foam plug and assemble luminaire.
- Remove cover plate, glass and seal.
- Join Quick Connectors (do not dispose of cap).

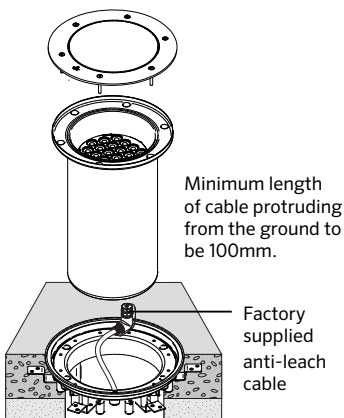

Step 10

Ensure that luminaire is acclimatized. Remove moisture sachet from packet supplied with lid assembly, remove gimbal from luminaire body and drop the sachet in the base of luminaire body.

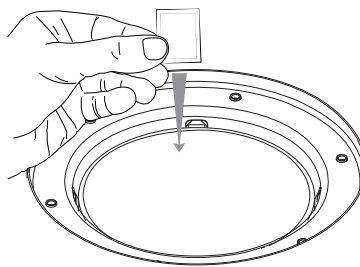

To prevent condensation, ensure luminaire is acclimatized (at same temperature as environment) before installation. Do not remove sachet from sealed packaging at this stage.

Step 11

Rotate gimbal until **Aiming Mark** is targeted as desired.

Lock Gimbal. Whilst exerting downward pressure on gimbal, tighten rotational lock grub screw.

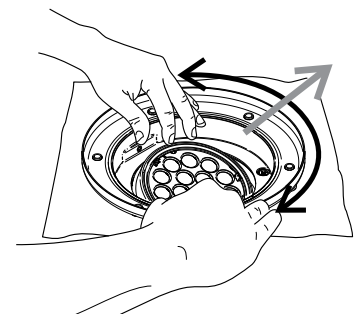

Installation

Step 12

Adjust gimbal tilt angle by rotating Tilt
Adjust screw with Allen key supplied.

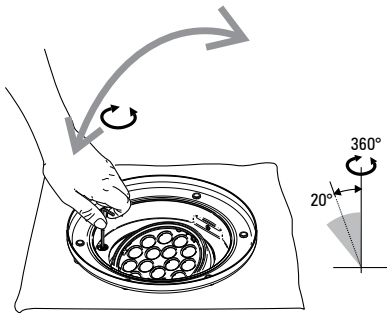

Step 13

Lay lid partially over luminaire to allow a gap for any moisture present to evaporate prior to sealing. Connect to supply and allow to burn for 2 hours.

IMPORTANT: Do not energise without partially covering gimbal.

Alternatively, using heat gun set at 100°C, heat the inside of luminaire at a distance of 300mm away for 10 minutes.

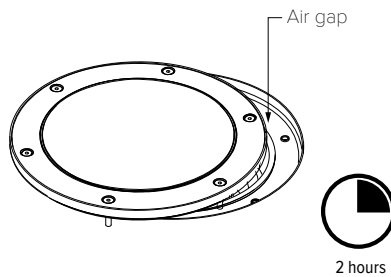

Step 14

Seal immediately after de-energising. Ensure seal and sealing surface is clean. Clean glass if necessary. Tighten lid screws using the 3mm allen key supplied. Ensure seal/sealing surface is free from debris. Lumascape recommends tightening using the torque pattern below.

Do not overtighten screws, 3Nm max.

